

LINK CONCORDANCE IMPLIES LINK HOMOTOPY

CHARLES H. GIFFEN*

Abstract.

We prove that concordant links in any 3-manifold are homotopic in the sense of J. Milnor. The proof is geometrical.

0. Introduction.

The object of this paper is to prove the theorem of the title, namely that link concordance implies link homotopy, for links in any 3-manifold (orientable or not). Link concordance was first studied for knots (links with one component) in the 3-sphere by Fox and Milnor almost twenty years ago, although their results lay unpublished for nearly a decade [2]. Link homotopy was introduced and extensively studied by Milnor [3], with refinements made possible by his subsequent work on isotopy of links [4; Theorems 8, 9].

Yet another link equivalence relation, I-equivalence, was introduced by Stallings for the purpose of obtaining a generalization [5] of the Chen–Milnor theorem [4; Theorem 2]. From this it follows readily that the Milnor link homotopy $\bar{\mu}$ -invariants [4; Theorem 8] are link concordance invariants as well (cf. also Casson [1]). Thus, our result should come as no surprise.

Actually, we also obtain the seemingly stronger result that PL- I-equivalence of links implies link homotopy; however, a little reflection reveals that the strength of this generalization is more apparent than real.

Our proofs are entirely geometric and quite elementary. The only significant external ingredient is a reduction made possible by a result of Tristram [6], also entirely geometric, extended in a routine way to arbitrary 3-manifolds. D. Goldsmith has also obtained a somewhat different proof that link concordance implies link homotopy.

1. Definitions and notational conventions.

We emphasize that 3-manifolds will *not* be assumed to be either orientable or without boundary. Furthermore, we work entirely within the PL (piecewise linear) category.

* Supported by NFS grants and a University of Virginia Sesquicentennial Research Associateship.

Received August 8, 1977.

Fix a positive integer v and let

$$S(v) = \coprod^v S^1 = \{1, \dots, v\} \times S^1$$

with components $S_j = \{j\} \times S^1 \subseteq S(v)$ for $j = 1, \dots, v$. A link with v components (or v -link) in a 3-manifold M^3 is an imbedding

$$l: S(v) \hookrightarrow \text{Int } M^3.$$

For $j = 1, \dots, v$ the j th component knot of l is the knot $l(j): S^1 \hookrightarrow M^3$ given by $l(j)(\zeta) = l(j, \zeta)$, $\zeta \in S^1$.

We shall consider the following equivalence relations on links in M^3 . Let $l_0, l_1: S(v) \hookrightarrow M^3$ be v -links.

(1) *Congruence (ambient isotopy)*: $l_0 \equiv l_1$ via h_s if $h_s: M^3 \rightarrow M^3$, $0 \leq s \leq 1$, is an isotopy of M^3 such that $h_0 = 1_{M^3}$ and $l_1 = h_1 \circ l_0$.

Notice that the trace

$$\mathcal{H}: M^3 \times I \rightarrow M^3 \times I$$

of h_s , given by $\mathcal{H}(x, s) = (h_s(x), s)$, is a homeomorphism. We may assume without loss of generality that $h_s|_{\partial M^3} = 1_{\partial M^3}$ (exercise).

(2) *Concordance*: $l_0 \approx l_1$ via \mathcal{L} if $\mathcal{L}: S(v) \times I \hookrightarrow \text{Int } M^3 \times I$ is a locally flat imbedding such that

$$\mathcal{L}^{-1}(\text{Int } M^3 \times \{i\}) = S(v) \times \{i\}$$

and $\mathcal{L}(x, i) = l_i(x)$ for $i = 0, 1$. Clearly if $l_0 \equiv l_1$ via h_s , then $l_0 \approx l_1$ via $\mathcal{L} = \mathcal{H} \circ (l_0 \times 1_I)$, where \mathcal{H} is the trace of h_s .

(3) *PL-I-equivalence*: $l_0 \approx l_1$ via \mathcal{L} if $\mathcal{L}: S(v) \times I \hookrightarrow \text{Int } M^3 \times I$ is an embedding (not necessarily locally flat) such that $\mathcal{L}^{-1}(\text{Int } M^3 \times \{i\}) = S(v) \times \{i\}$ and $\mathcal{L}(x, i) = l_i(x)$ for $i = 0, 1$. Clearly, a concordance \mathcal{L} is always a PL-I-equivalence, but not conversely [2].

(4) *Homotopy*: $l_0 \simeq l_1$ via l_s if $l_s: S(v) \rightarrow \text{Int } M^3$, $0 \leq s \leq 1$ is a continuous 1-parameter family of maps such that $l_s S_j \cap l_s S_{j'} = \emptyset$ for $1 \leq j < j' \leq v$. Clearly, if $l_0 \equiv l_1$ via h_s , then $l_0 \simeq l_1$ via $l_s = h_s \circ l_0$.

If N is a surface and C is a union of (some, not necessarily all) components of ∂N , a ribbon map with respect to C in M^3 is a transverse immersion $\mathcal{J}: N \hookrightarrow \text{Int } M^3$ whose singularities are all ribbon singularities with respect to C ; that is to say, \mathcal{J} is a locally flat local imbedding, and the only multiple points of \mathcal{J} are double points with the following properties:

(i) each component of the *singular locus* $\Sigma(\mathcal{J})$ of \mathcal{J} is an arc, called a *singular arc* of \mathcal{J} ;

(ii) if A is a singular arc of \mathcal{J} (notation: $A \in \pi_0 \Sigma(\mathcal{J})$), then $\mathcal{J}^{-1}A$ is the disjoint union of two arcs, each mapped homeomorphically onto A by \mathcal{J} , of which one, denoted A' , is a *spanning arc* (with respect to C) and the other, denoted A'' , is an *interior arc*—i.e.,

$$\partial A' = A' \cap \partial N \subseteq C, \quad A'' \subseteq \text{Int } N .$$

Note that $\mathcal{J}|_{\partial N}$ is necessarily an imbedding. As further notation, let

$$\Delta'(\mathcal{J}) = \bigcup_{A \in \pi_0 \Sigma(\mathcal{J})} A', \quad \Delta''(\mathcal{J}) = \bigcup_{A \in \pi_0 \Sigma(\mathcal{J})} A'' ;$$

also, let $\Delta = \Delta' \cup \Delta''$. Finally, let $A' \in \pi_0 \Delta'(\mathcal{J})$, $A'' \in \pi_0 \Delta''(\mathcal{J})$, and $A \in \pi_0 \Sigma(\mathcal{J})$ be equivalent statements in the obvious sense.

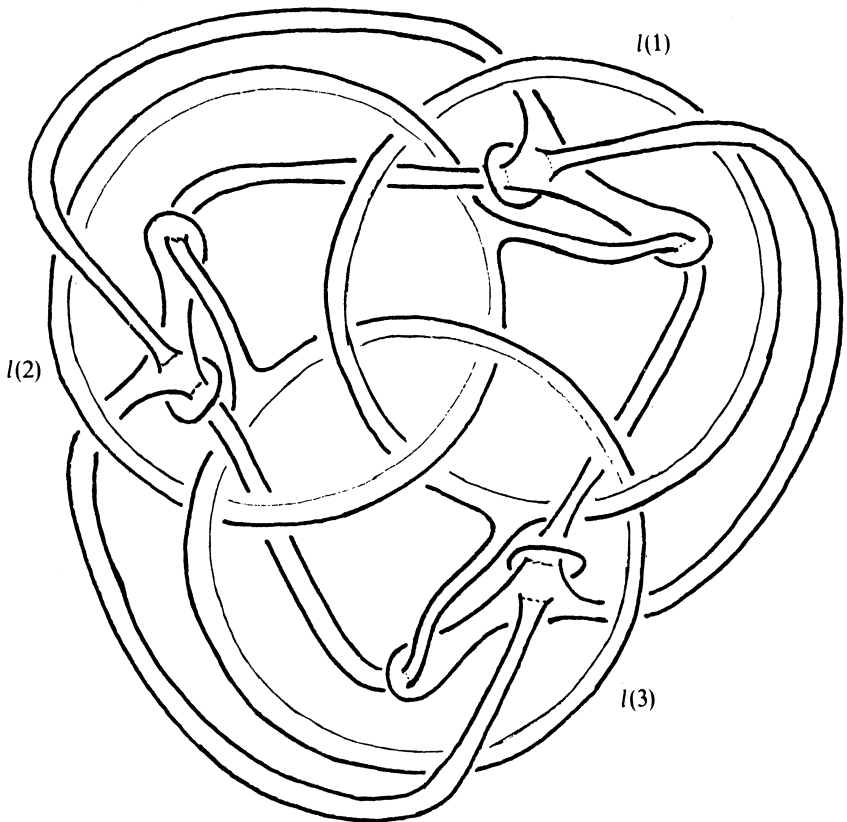

Figure 1. An amebiotopy from a 3-link l to the Borromean rings. The 9 ribbon singularities are also indicated.

With this done, we define the key (non-equivalence) relation needed for our study of concordance. Again, l_0, l_1 are ν -links in M^3 .

(5) *Ameibeitopy*: $l_0 \twoheadrightarrow l_1$ via the ameibeitopy \mathcal{X} if

$$\mathcal{X} : S(\nu) \times I \looparrowright \text{Int } M^3$$

is a ribbon map with respect to $S(\nu) \times \{0\}$ such that $\mathcal{X}(x, i) = l_i(x)$ for $i = 0, 1$. Figure 1 suggests the image of an ameibeitopy from a rather bizarre 3-link to the Borromean rings.

Now if $l_0 \twoheadrightarrow l_1$ via \mathcal{X} , then $l_0 \approx l_1$ via $\mathcal{L} = (\mathcal{X}, \sigma)$ where $\sigma : S(\nu) \times I \rightarrow I$ is any (PL) map such that $\sigma^{-1}(i) = S(\nu) \times \{i\}$ for $i = 0, 1$ and

$$\sigma(x, s) \begin{cases} < 1/2 & \text{for } (x, s) \in \Delta' \mathcal{X} \\ > 1/2 & \text{for } (x, s) \in \Delta'' \mathcal{X} . \end{cases}$$

(Such maps σ clearly exist.) This idea is due to Fox.

It will be convenient, for an ameibeitopy \mathcal{X} , to set

$$\Delta'_j(\mathcal{X}) = \Delta'(\mathcal{X}) \cap S_j \times I, \quad \Delta''_j(\mathcal{X}) = \Delta''(\mathcal{X}) \cap S_j \times I$$

and, if $A \in \pi_0 \Sigma(\mathcal{X})$, to define

$$\delta' A = \text{unique } j \text{ such that } A' \subseteq \Delta'_j(\mathcal{X}),$$

$$\delta'' A = \text{unique } j \text{ such that } A'' \subseteq \Delta''_j(\mathcal{X}).$$

2. Ameibeitopy and concordance.

We have noted above that ameibeitopy implies concordance, i.e. if l_0, l_1 are ν -links in M^3 and if $l_0 \twoheadrightarrow l_1$, then $l_0 \approx l_1$. In this section we sketch a proof that shows the reverse implication holds, provided ameibeitopy is replaced by the equivalence relation it generates. In other words, concordance is the equivalence relation generated by ameibeitopy. The essential ingredients are Tristram's results [6] and the following, details of which are a routine exercise.

(2.1) LEMMA. *Let $\mathcal{J} : N \looparrowright \text{Int } M^3$ be a ribbon map with respect to $C \subseteq \partial N$ and let $b : I \times I \looparrowright \text{Int } M^3$ be compatible with $\mathcal{J}C$ (i.e. $b(I \times I) \cap \mathcal{J}C = b(I \times \partial I)$). Then there is an ambient isotopy $h_s : M^3 \rightarrow M^3$, $0 \leq s \leq 1$, supported in any prescribed neighborhood of $b(I \times I)$, such that $h_0 = 1_{M^3}$, $h_s \mathcal{J}C = \mathcal{J}C$, and, if*

$$N' = N \coprod I \times I / (\mathcal{J}^{-1} h_1 b(t, i) \sim (t, i) \mid (t, i) \in I \times \partial I),$$

then $\mathcal{J}' = \mathcal{J} \cup h_1 \circ b : N' \looparrowright \text{Int } M^3$ is a ribbon map with respect to

$$C' = \partial N' - (\partial N - C) = \overline{C - \mathcal{J}^{-1} h_1 b(I \times \partial I)} \coprod \partial I \times I / \sim .$$

The idea of the proof is to move the “band” b so as to intersect the map \mathcal{J} as “nicely as possible”, relative to $\mathcal{J}C$, the movement being accomplished by h_s , with end result the nice band $h_1 \circ b$.

Let l_0, l_1 be v -links in M^3 and let $L_i = l_i S(v)$ with orientation and ordering of components induced from the canonical ones on $S(v)$. Then Tristram [6; 1.15] has defined a relation $L_1 \xrightarrow{r} L_0$.

(2.2) PROPOSITION. *Let l_0, l_1 be v -links in M^3 :*

- (a) *if $l_0 \rightarrow l_1$, then $L_1 \xrightarrow{r} L_0$;*
- (b) *if $L_1 \xrightarrow{r} L_0$, then $l_0 \equiv l'_0 \rightarrow l'_1 \equiv l_1$ for some v -links l'_0, l'_1 .*

PROOF. Part (a) is left as an easy exercise, since it is not required in the sequel. Part (b) is sketched as follows. Now $L_1 \xrightarrow{r} L_0$ involves a ribbon map

$$\mathcal{G}: \{1, \dots, \mu\} \times D^2 \hookrightarrow M^3 - L_1$$

(with respect to $\{1, \dots, \mu\} \times S^1$) and μ “bands” $b_1, \dots, b_\mu: I \times I \hookrightarrow M^3$ with

$$L_0 \equiv (\dots ((L_1 +_{b_\mu} \{\mu\} \times S^1) +_{b_{\mu+1}} \{\mu - 1\} \times S^1) \dots +_{b_1} \{1\} \times S^1)$$

(in Tristram’s notation). We may choose an imbedding

$$\mathcal{J}: S(v) \times I \hookrightarrow \text{Int } M^3 - \mathcal{G}(\{1, \dots, \mu\} \times D^2)$$

with $l_1(x) = \mathcal{J}(x, 0)$ (note $l_1 \equiv l'_1$ where $l'_1(x) = \mathcal{J}(x, 1)$). For each non-negative integer λ , let

$$N(v, \lambda) = S(v) \times I \cup \{1, \dots, \lambda\} \times D^2,$$

$$C(v, \lambda) = S(v) \times \{0\} \cup \{1, \dots, \lambda\} \times S^1.$$

Then we may apply (2.1) to $N = N(v, \mu)$, $C = C(v, \mu)$, $\mathcal{J} = \mathcal{J} \cup \mathcal{G}$, and $b = b_\mu$ obtaining, via h_s , $N' \cong N(v, \mu - 1)$, $C' \cong C(v, \mu - 1)$, \mathcal{J}' . If $\mu - 1 > 0$, set $b' = h_1 b_{\mu - 1}$ and apply (2.1) to this situation obtaining, via h'_s say, $N'' \cong N(v, \mu - 2)$, $C'' \cong C(v, \mu - 2)$, \mathcal{J}'' . A total of μ applications of (2.1) are possible, the $(i + 1)$ st to $N^{(i)} \cong N(v, \mu - i)$, $C^{(i)} \cong C(v, \mu - i)$, $b^{(i)} = h_1^{(i-1)} \dots h'_1 h_1 b_{\mu - i}$ yielding, via $h_s^{(i)}$, $N^{(i+1)}$, $C^{(i+1)}$, $\mathcal{J}^{(i+1)}$, $i < \mu$. The end product is $N^{(\mu)} \cong N(v, 0) = S(v) \times I$, $C^{(\mu)} \cong S(v) \times \{0\}$, and the resulting $\mathcal{J}^{(\mu)} \cong \mathcal{K}$ an amebitopy $l'_0 \rightarrow l'_1$, where $l_0 \equiv l'_0$. Since $l'_1 \equiv l_1$ as noted above, the result follows.

(2.3) THEOREM. *If l, l' are v -links in a 3-manifold M^3 , then $l \approx l'$ if and only if there are v -links l_0, l_1, \dots, l_q in M^3 such that $l = l_0$, $l' \cong l_q$ and for $i = 1, \dots, q$, either $l_{i-1} \rightarrow l_i$ or $l_i \rightarrow l_{i-1}$.*

PROOF. The “only if” part is all that needs proof. However, this follows from (2.2) and [6; 1.32] (the apparent intermediate congruences may be moved to

the end of the string). We point out that Tristram's results (and proofs) generalize routinely to arbitrary M^3 (instead of just R^3).

3. Desingularizing ameibeitopies.

Our main result is the following.

(3.1) THEOREM. *Let l_0, l_1 be ν -links in the 3-manifold M^3 ; if $l_0 \approx l_1$, then $l_0 \simeq l_1$.*

By (2.3) it suffices to prove the following.

(3.2) PROPOSITION. *Let l_0, l_1 be ν -links in the 3-manifold M^3 ; if $l_0 \twoheadrightarrow l_1$, then $l_0 \simeq l_1$.*

REMARKS. The proof of (3.2) is actually *constructive*. That is, given $l_0 \twoheadrightarrow l_1$ via \mathcal{X} , the proof provides a recipe for producing, out of \mathcal{X} , a more-or-less specific homotopy from l_0 to l_1 . As a special case, let us call the ameibeitopy \mathcal{X} above *special* if, for each $A \in \pi_0 \Sigma(\mathcal{X})$, $\delta' A = \delta'' A$ — i.e. for some $j = 1, \dots, \nu$, $A' \cup A'' \subseteq S_j \times I$. The following is trivial.

(3.3) LEMMA. *If $l_0 \twoheadrightarrow l_1$ via special \mathcal{X} , then $l_0 \simeq l_1$ via $l_s = \mathcal{X} \circ (1_{S(\nu)}, s)$.*

We now set about defining the complexity of an ameibeitopy, which will be used in the proof of (3.2) (instead of a multiple induction). Let \mathcal{X} be an ameibeitopy of ν -links in M^3 . If $A \in \pi_0 \Sigma(\mathcal{X})$ with $\delta' A \neq \delta'' A$, then $A' \in \pi_0 \Delta'(\mathcal{X})$ is a *bad* spanning arc. If $B \in \pi_0 \Sigma(\mathcal{X})$ with $\delta' B = \delta'' B = j$ and if a bad $A' \in \pi_0 \Delta'(\mathcal{X})$ separates $S_j \times \{1\}$ from either B' or B'' , then $B'' \in \pi_0 \Delta''(\mathcal{X})$ is a *bad interior arc*. For $j = 1, \dots, \nu$, let

$$m'_j = m'_j(\mathcal{X}) = \text{card} \{A' \in \pi_0 \Delta'_j(\mathcal{X}) \mid A' \text{ is bad}\}$$

$$m''_j = m''_j(\mathcal{X}) = \text{card} \{B'' \in \pi_0 \Delta''_j(\mathcal{X}) \mid B'' \text{ is bad}\}$$

and set $m_j = m_j(\mathcal{X}) = m'_j(\mathcal{X}) + m''_j(\mathcal{X})$. Let $\mathbf{Z}_+ = \{n \in \mathbf{Z} \mid n \geq 0\}$ and define the *complexity* $m(\mathcal{X})$ of \mathcal{X} to be the ν -tuple

$$m(\mathcal{X}) = (m_1(\mathcal{X}), \dots, m_\nu(\mathcal{X})) \in (\mathbf{Z}_+)^{\nu}.$$

Let $(\mathbf{Z}_+)^{\nu}$ have the *lexicographic well-ordering*: $(m_1, \dots, m_\nu) < (n_1, \dots, n_\nu)$ if and only if for some $j = 1, \dots, \nu$ and for all $i = 1, \dots, j - 1$, $m_i = n_i$ and $m_j < n_j$. The following is immediate from the definitions.

(3.4) LEMMA. *If $l_0 \twoheadrightarrow l_1$ via \mathcal{X} , then $m_j(\mathcal{X}) = 0$ if and only if $m'_j(\mathcal{X}) = 0$; in particular, the following statements are equivalent:*

- (a) \mathcal{X} is special;
- (b) \mathcal{X} has no bad spanning arcs;
- (c) $m(\mathcal{X}) = (0, \dots, 0)$.

The following will be used to eliminate bad interior arcs (and could be used to eliminate any $A \in \pi_0 \Sigma(\mathcal{X})$ such that $\delta' A = \delta'' A$).

(3.5) PROPOSITION. *Let l_0, l_1 be v -links in the 3-manifold M^3 and let $l_0 \rightsquigarrow l_1$ via \mathcal{X} ; furthermore, let $A \in \pi_0 \Sigma(\mathcal{X})$ be such that $\delta' A = \delta'' A = j$. Then:*

- (1) *there is a disc $D \subseteq S_j \times I$ such that*

$$T = D \cap S_j \times \partial I \subseteq \partial D \cap S_j \times \{0\}$$

is an arc and such that $A'' = D \cap \Delta(\mathcal{X}) \subseteq \text{Int } D$;

- (2) *if $D \subseteq S_j \times I$ is any disc satisfying (1), then there is an isotopy of imbeddings $g_s: S(v) \times I \hookrightarrow S(v) \times I, 0 \leq s \leq 1$, with $g_0 = 1$ and supported on $\text{Int } D \cup \text{Int } T \subseteq D$ such that $A'' \cap g_1(S(v) \times I) = \emptyset$;*

- (3) *if g_s is any isotopy satisfying (2), and if $\mathcal{X}'_s = \mathcal{X} \circ g_s$ and $l'_s = \mathcal{X}'_s \circ (1_{S(v)}, 0)$, then l'_1 is a v -link in $M^3, l_0 = l'_0 \simeq l'_1$ via $l'_s, l'_1 \rightsquigarrow l_1$ via \mathcal{X}'_1 , and $\Sigma(\mathcal{X}'_1) = \Sigma(\mathcal{X}) - A$.*

PROOF. For (1) observe that since every component of $\Delta(\mathcal{X})$ is an arc, $\Delta(\mathcal{X}) - A''$ cannot separate the interior arc A'' from $S_j \times \{0\}$; hence, we may choose an arc

$$J \subseteq S_j \times [0, 1) - (\Delta(\mathcal{X}) - A'')$$

which meets A'' in one endpoint of J and $S_j \times \{0\}$ in the other endpoint of J . Now we take D to be a regular neighborhood of the tree $A'' \cup J$ in $S_j \times [0, 1) - (\Delta(\mathcal{X}) - A'')$. See Figure 2 “before”. For (2) we must have

$$g_s|_{S(v) \times I - (\text{Int } D \cup \text{Int } T)} = 1;$$

hence, g_s is completely determined by $g'_s = g_s|_D: D \hookrightarrow D$, where $g'_0 = 1, g'_s|_{\partial D - T} = 1$, and $g'_1(D) \cap A'' = \emptyset$. But this is easy to arrange. Finally, (3) is simply an observation about the effect of g_s on the situation. Figure 2 “after” tells all.

To dispatch bad spanning arcs we must be rather more circumspect. First, note that for any spanning arc $A' \in \pi_0 \Delta'_j(\mathcal{X})$, the closure of one of its complementary domains in $S_j \times I$ is a disc $D(A')$ (the other is an annulus). Let us call $A' \in \pi_0 \Delta'_j(\mathcal{X})$ *extremal* if its disc $D(A')$ contains (and hence meets) no other spanning arc of \mathcal{X} . Since $\pi_0 \Delta'_j(\mathcal{X})$ is a finite set, then for any $j = 1, \dots, v$ there is an extremal $A' \in \pi_0 \Delta'_j(\mathcal{X})$ or else $\Delta'_j(\mathcal{X}) = \emptyset$. Extremal bad spanning arcs will be handled with the aid of the following (compare Figure 3).

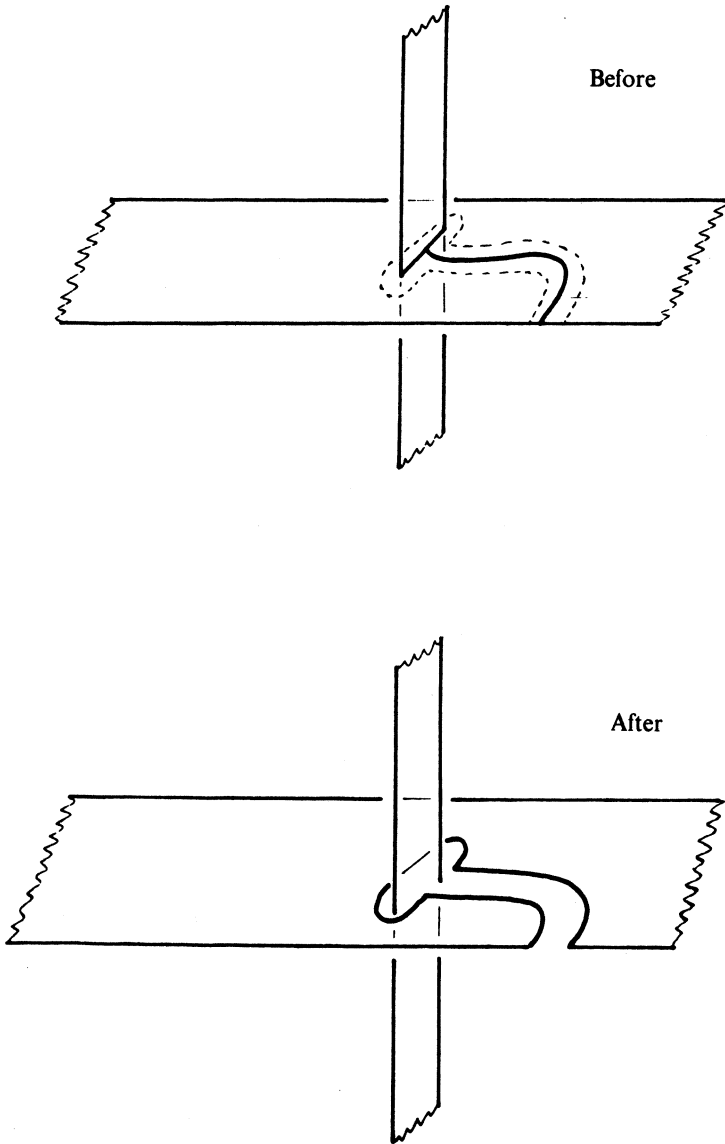

Figure 2. Removing a (bad) interior arc.

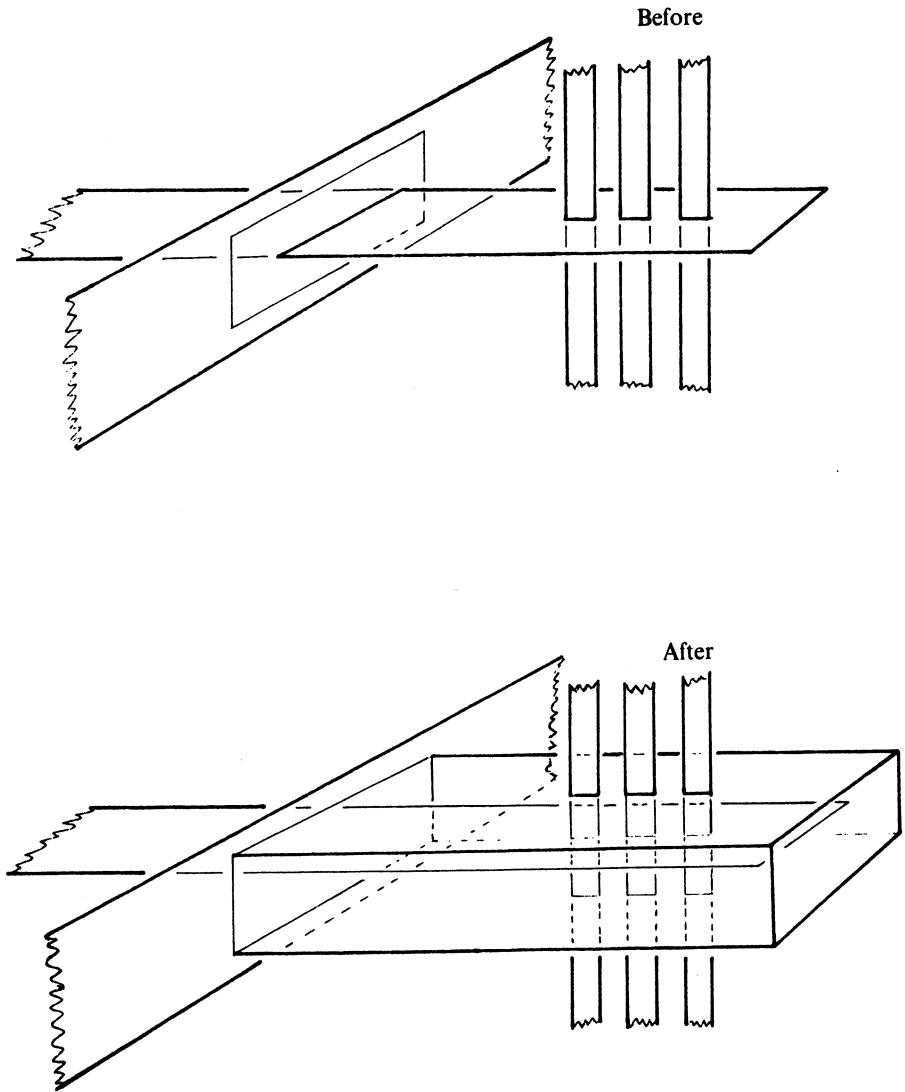

Figure 3. Removing an extremal spanning arc.

(3.6) PROPOSITION. Let l_0, l_1 be ν -links in the 3-manifold M^3 and let $l_0 \rightsquigarrow l_1$ via \mathcal{K} . Suppose $A' \in \pi_0 \Delta'_j(\mathcal{K})$ is extremal and that its corresponding $A'' \not\subseteq D(A')$ (and hence $A'' \cap D(A') = \emptyset$). Then there is a regular homotopy

$$\mathcal{K}_s: S(\nu) \times I \hookrightarrow \text{Int } M^3,$$

supported on a disc D satisfying $D \cap \Delta(\mathcal{K}) = A'' \subseteq \text{Int } D$, such that $\mathcal{K}_0 = \mathcal{K}$, $\mathcal{K}_s|_D$ is an isotopy of imbeddings (stationary on ∂D), and

$$l_0 \rightsquigarrow l_1 \text{ via } \mathcal{K}_1$$

with the following properties: if $A'_i \in \pi_0 \Delta'_j(\mathcal{K})$ for $i = 1, \dots, q$ denote the distinct (interior) arcs such that

$$\Delta'(\mathcal{K}_1) = (\Delta'(\mathcal{K}) - A') \cup A'_{q+1} \cup \dots \cup A'_{3q} \quad (\text{disjoint}),$$

where, for $i = 1, \dots, q$, $\delta' A'_i = \delta' A_{q+i} = \delta' A_{2q+i} = j_i$, say, and A'_{q+i}, A'_{2q+i} cobound a disc D_i in $S_{j_i} \times [0, 1)$, that is

$$\partial D_i = A'_{q+i} \cup A'_{2q+i} \cup (D_i \cap S_{j_i} \times \{0\}),$$

such that $A'_i \cup A'_{q+i} \cup A'_{2q+i} = D_i \cap \Delta(\mathcal{K}_1)$ and A'_i separates A'_{q+i} from A'_{2q+i} ; moreover, the corresponding interior arcs $A''_{q+1}, \dots, A''_{3q} \in \pi_0 \Delta''(\mathcal{K}_1)$ all lie in $\text{Int } D$.

PROOF. Triangulate $S(\nu) \times I$, M^3 so that \mathcal{K} is simplicial. Note that the condition $A'' \not\subseteq D(A')$ and the extremality of A' guarantee that $\mathcal{K}|_{D(A')}$ is an imbedding. Let V be the star of $\mathcal{K}(D(A'))$ in a second derived subdivision of the triangulation of M^3 . Then V is a 3-cell, and $V \cap \mathcal{K}(S(\nu) \times I)$ is a regular neighborhood of $\mathcal{K}(D(A'))$ in $\mathcal{K}(S(\nu) \times I)$; hence $\mathcal{K}^{-1}V$ is a regular neighborhood of

$$\mathcal{K}^{-1}\mathcal{K}(D(A')) = D(A') \cup A'' \cup A'_1 \cup \dots \cup A'_q \quad (\text{disjoint})$$

in $S(\nu) \times I$. We may take D to be the component of $\mathcal{K}^{-1}V$ containing A'' . Then $\mathcal{K}(D)$ is a disc which spans V , i.e. $\mathcal{K}(D) \cap \partial V = \mathcal{K}(\partial D)$. The two complementary domains of $\mathcal{K}(D)$ in V have closures which are also 3-cells, and one of these, E say, contains $\mathcal{K}(D(A'))$. We now take \mathcal{K}_s to be defined by requiring $\mathcal{K}_s(x) = \mathcal{K}(x)$ for $s = 0$ or $x \notin \text{Int } D$, $\mathcal{K}_s|_D: D \hookrightarrow E$, and $\mathcal{K}_1(D) = E \cap \partial V = \overline{\partial E - \mathcal{K}(D)}$ (this is easy to achieve). The rest of the proof is now routine. For example, D_i is just the component of $\mathcal{K}^{-1}V$ which contains A_i .

PROOF OF (3.2). If $m(\mathcal{K}) = (0, \dots, 0)$, then (3.2) follows from (3.4) and (3.3). Since $(\mathbb{Z}_+)^n$ is well-ordered with least element $(0, \dots, 0)$, it suffices to show that if $m(\mathcal{K}) \neq (0, \dots, 0)$, then there exists a ν -link l'_1 in M^3 such that $l_0 \simeq l'_1$ and $l'_1 \rightsquigarrow l_1$ via some \mathcal{K}_1 with $m(\mathcal{K}_1) < m(\mathcal{K})$. If $m(\mathcal{K}) \neq (0, \dots, 0)$, then for some

unique $j_0 = 1, \dots, v$, $m_{j_0}(\mathcal{X}) \neq 0$ and $m_j(\mathcal{X}) = 0$ for $j > j_0$; also, $m'_{j_0}(\mathcal{X}) \neq 0$ by (3.4). Now let Γ be the collection of those extremal $A' \in \pi_0 \Delta'_{j_0}(\mathcal{X})$ such that (1) either A' is bad or the corresponding interior arc A'' is bad ($\delta'' A = j_0$) and (2) $D(A')$ contains no bad interior arc B'' of \mathcal{X} ; in particular, if $A' \in \Gamma$, then $A'' \not\subseteq D(A')$. Note that if $m'_{j_0}(\mathcal{X}) = 0$, then $\Gamma \neq \emptyset$, and the elements of Γ are bad; hence, if $\Gamma = \emptyset$, then $m'_{j_0}(\mathcal{X}) \neq 0$. If $\Gamma \neq \emptyset$, choose $A' \in \Gamma$ and apply (3.6) with $j = j_0$. Since $m_{j'}(\mathcal{X}) = 0$ for $j' > j_0$ and since $D(A')$ contains no bad interior arc B'' of \mathcal{X} , then for any $i = 1, \dots, q$ as in (3.6), $j_i < j_0$. Therefore $m_{j'}(\mathcal{X}_1) = 0$ for $j' > j_0$; in addition, condition (2) above guarantees that $m_{j_0}(\mathcal{X}_1) = m_{j_0}(\mathcal{X}) - 1$. Hence, $m(\mathcal{X}_1) < m(\mathcal{X})$ and $l_0 \rightsquigarrow l_1$ via \mathcal{X}_1 as required. If, on the other hand, $\Gamma = \emptyset$, then $m'_{j_0}(\mathcal{X}) \neq 0$ as remarked above, and so we choose a bad $A' \in \pi_0 \Delta'_{j_0}(\mathcal{X})$ and apply (3.5) with $A = \mathcal{X}(A')$. This yields $l_0 \simeq l'_1$ via l'_s and $l'_1 \rightsquigarrow l_1$ via \mathcal{X}_1 with $m_{j_0}(\mathcal{X}_1) = m_{j_0}(\mathcal{X}) - 1$, $m_{j'}(\mathcal{X}_1) = m_{j'}(\mathcal{X})$ for $j' \neq j_0$, and so $m(\mathcal{X}_1) < m(\mathcal{X})$. This completes the proof of (3.2) and also of (3.1).

REMARK. We have chosen the “most efficient” simplifying procedure in the choice of complexity and proof just given, in that only as a “last resort” do we invoke (3.5), which actually causes l_0 to be “moved”. The most “gross” procedure from this standpoint seems to be to define a different complexity $n(\mathcal{X}) = (n_1(\mathcal{X}), \dots, n_v(\mathcal{X})) \in (\mathbb{Z}_+)^v$ where

$$n_j(\mathcal{X}) = \text{card } \pi_0 \Delta'_j(\mathcal{X}).$$

In this situation, if for some $j_0 = 1, \dots, v$, $n_{j_0}(\mathcal{X}) \neq 0$ and $n_j(\mathcal{X}) = 0$ for $j > j_0$, then we would use (3.5) if $m'_{j_0}(\mathcal{X}) < n_{j_0}(\mathcal{X})$ and (3.6) if $m'_{j_0}(\mathcal{X}) = n_{j_0}(\mathcal{X})$ to reduce the complexity. Of course, if $n(\mathcal{X}) = (0, \dots, 0)$ then $l_0 \equiv l_1$.

4. Piecewise linear I-equivalence implies link homotopy.

We sketch here a proof of the following.

(4.1) THEOREM. *If l_0, l_1 are v -links in the 3-manifold M^3 and if $l_0 \stackrel{\perp}{\simeq} l_1$, then $l_0 \simeq l_1$.*

PROOF. Without loss of generality we may assume that all points of non-local flatness of \mathcal{L} (where $l_0 \stackrel{\perp}{\simeq} l_1$ via \mathcal{L}) are interior to $S(v) \times I$. In each $S_j \times I$, $j = 1, \dots, v$, choose an arc J_j which contains all of the non-locally flat points of \mathcal{L} lying in $S_j \times I$ such that J_j meets $S_j \times \partial I$ in just one of its endpoints lying, say, in $S_j \times \{0\}$. Using these arcs J_j , we may deform \mathcal{L} by an isotopy stationary on $S(v) \times \partial I$ the non-locally flat points of (the deformed) \mathcal{L} are on $S(v) \times \{0\}$ and so that each $S_j \times \{0\}$ contains (at most) one non-locally flat point. Introducing (by PL isotopy of l_0) the reflected inverse of the local knot thus

determined on each component, we may now resolve the non-local flatness which is now slice. We have shown that l_0 is PL-isotopic to a link which is concordant to l_1 . Now (3.1) and the fact that isotopy of links implies homotopy of links give the desired conclusion.

BIBLIOGRAPHY

1. A. J. Casson, *Link cobordism and Milnor's invariant*, Bull. London Math. Soc. 7 (1975), 39–40.
2. R. H. Fox and J. W. Milnor, *Singularities of 2-spheres in the 4-sphere*, Osaka Math. J. 3 (1966), 257–267.
3. J. W. Milnor, *Link groups*, Ann. of Math. 59 (1954), 177–195.
4. J. W. Milnor, *Isotopy of links*, Algebraic Geometry and Topology (a Symposium in honor of Solomon Lefschetz), 280–306, Princeton, 1957.
5. J. R. Stallings, *Homology and central series of groups*, J. Algebra 2 (1965), 170–181.
6. A. G. Tristram, *Some cobordism invariants for links*, Proc. Cambridge Philos. Soc. 66 (1969), 251–264.

INSTITUTE FOR ADVANCED STUDY
PRINCETON, N.J. 08540, U.S.A.

AND

UNIVERSITY OF VIRGINIA
CHARLOTTESVILLE, VA. 22903, U.S.A.