

## AN INEQUALITY FOR HILBERT SERIES OF GRADED ALGEBRAS

RALF FRÖBERG

### Introduction.

We study in this paper rings of the type  $R = k[X_1, \dots, X_n]/I$ , where  $I$  is a homogeneous ideal and  $k$  is the field of complex numbers (in most cases any field will do). Given the embedding dimension, the Krull dimension, the depth and the degrees of a set of generators for  $I$ , we derive an inequality for the Hilbert function of  $R$ . We conjecture that this inequality can not be improved for Cohen-Macaulay rings, but we show by means of an example that the inequality is not sharp in general. We call a ring for which the inequality is an equality extremal. In section 3 we give lots of examples of extremal rings. It turns out that complete intersections are always extremal. Two classes of almost complete intersections (one which is Cohen-Macaulay and one which is not) also have extremal elements. These two classes are more closely studied in section 4.

The study of extremal rings can in many respects easily be reduced to a study of extremal rings of depth 0: For rings of depth 0 one can characterize the complete intersections by means of their Koszul homology,  $R$  being a complete intersection if and only if the multiplication map  $\wedge^n H_1(K_R) \rightarrow H_n(K_R)$  is injective, where  $n = e.\dim R$ , see [10]. We show that for the non-Cohen-Macaulay almost complete intersections mentioned above, we have  $\wedge H_1(K_R) \rightarrow H(K_R)$  as injective as it could be, i.e. that  $\wedge^{n-1} H_1(K_R)$  injects in  $H_{n-1}(K_R)$ .

For any graded ring  $R$ ,  $H(K_R)$  is bigraded and given  $\dim_k H_{i,j}(K_R)$  it is easy to calculate the Hilbert function of  $R$ . But in general one can not deduce  $\dim_k H_{i,j}(K_R)$  from the Hilbert function of  $R$ . One instance when this is possible is when one knows that there exists a minimal graded  $k[X_1, \dots, X_n]$ -resolution of  $R$  which is pure, i.e. when there exists a minimal resolution

$$0 \rightarrow F_r \rightarrow \dots \rightarrow F_1 \rightarrow k[X_1, \dots, X_n] \rightarrow R \rightarrow 0,$$

where all basis elements of a graded basis for  $F_i$  are of the same degree for  $i = 1, \dots, r$ . For the extremal rings mentioned above we do not have pure resolutions, but yet we can deduce not only the dimensions of  $H_{i,j}(K_R)$  but also

the structure of  $H(K_R)$  as bigraded algebra from the Hilbert function. This knowledge is used to show that their Poincaré series are rational and only depend on the embedding dimension.

We conclude by showing that though the non-Cohen-Macaulay almost complete intersections we study are close to complete intersections in some respects, they are not even Buchsbaum rings.

We end the introduction with a conjecture and a question proposed by our work.

**CONJECTURE.** If  $R$  is an Artinian graded  $k$ -algebra (or an Artinian local ring) of embedding dimension  $n$  with  $\wedge^s H_1(K_R)$  injective in  $H_s(K_R)$  for some  $s > [n/2]$ , then  $R$  is a complete intersection.

**QUESTION.** Does there exist a graded  $k$ -algebra (or a local ring)  $R$  of depth 0 which is not a complete intersection with  $\dim_k H_1(K_R) = r$  and with  $\wedge^r H_1(K_R)$  injective in  $H_r(K_R)$ ?

**0. Notations and conventions.**

By a ring we mean a ring of type  $R = k[X_1, \dots, X_n]/I$ , where  $k$  is the field of complex numbers and  $I$  is generated by forms  $f_1, f_2, \dots, f_r$  of degree  $> 1$ . The image of  $X_i$  in  $R$  is denoted  $x_i$ . The ring  $R$  is graded in the usual way,

$$R = \bigoplus_{i \geq 0} R_i,$$

we define

$$h_R(i) = \dim_k R_i, \quad \text{Hilb}_R(Z) = \sum_{i \geq 0} h_R(i)Z^i$$

and correspondingly for modules. For a given set of generators for  $I$ , the *numerical character* (n.c.) of  $R$  is  $T = (n, d, g, D)$ , if  $e.\dim R = n$ ,  $\dim R = d$ ,  $\text{depth } R = g$  and if  $f_1, \dots, f_r$  is the given system of generators for  $I$  with  $\deg f_i = d_i$ , then  $D = (d_1, \dots, d_r)$ . Let  $|D| = r$ .

If  $A(Z) = \sum_{i \geq 0} a_i Z^i$  and  $B(Z) = \sum_{i \geq 0} b_i Z^i$  are power series with integer coefficients, let

$$[A(Z)] = \sum_{i \geq 0} c_i Z^i$$

where  $c_i = a_j$  if  $a_j > 0$  for all  $j \leq i$  and  $c_i = 0$  otherwise, and let

$$\max(A(Z), B(Z)) = \sum_{i \geq 0} \max(a_i, b_i) Z^i.$$

Let  $A(Z) >^i B(Z)$  if for some  $i_0$  we have  $a_i = b_i$  if  $i < i_0$  and  $a_{i_0} > b_{i_0}$ . Let  $A(Z) \geq B(Z)$  if  $a_i \geq b_i$  for all  $i$ .

A form  $\sum_I c_I m^I$  of degree  $d$  in  $k[X_1, \dots, X_n]$  is called generic if all monomials of degree  $d$  in  $k[X_1, \dots, X_n]$  have coefficients  $c_I$  which are algebraically independent over  $\mathbb{Q}$ . An ideal  $(f_1, \dots, f_r)$  is generated by generic forms if all  $f_i = \sum_I c_I^{(i)} m^I$  are generic forms and all  $c_I^{(i)}$  are algebraically independent over  $\mathbb{Q}$ . If  $I$  is generated by generic forms we call  $k[X_1, \dots, X_n]/I$  generic.

A ring  $R$  of n.c.  $(n, d, g, D)$  has complete intersection defect  $\text{def } R = |D| - n + d$ . If  $\text{def } R = 0$ ,  $R$  is a complete intersection and if  $\text{def } R = 1$ ,  $R$  is an almost complete intersection. (Here we assume  $f_1, \dots, f_r$  to be a minimal system of generators for  $I = (f_1, \dots, f_r)$ .)

The Koszul complex of  $R$  is

$$K_R = R \langle T_1, \dots, T_n; dT_i = x_i \rangle .$$

Its cycles, boundaries respectively homology are denoted by  $Z(K_R)$ ,  $B(K_R)$ , and  $H(K_R)$  respectively. The homology  $H(K_R)$  is not changed by a linear transformation of the  $x_i$ 's, nor by factoring out a non-zero divisor of degree one. The complex  $K_R$  (and so  $Z(K_R)$ ,  $B(K_R)$  and  $H(K_R)$ ) is bigraded. Besides homological degree it has a grading induced by the grading of  $R$  (total degree). We find it simpler in this context to refer to total degree minus homological degree as ring degree, thus  $x_1 T_2 T_3$  in  $K_R$  has total degree 3, homological degree 2 and ring degree 1. The differential has degree 0,  $-1$  respectively  $+1$  in total, homological and ring degree respectively. If we have one index on  $K_R$  (or  $Z(K_R)$  or  $\dots$ ), we always mean homological degree. If we have two indexes the first means homological degree and the second ring degree.

The Poincaré series of  $R$  is defined as

$$P_R(Z) = \sum_{i \geq 0} \dim_k (\text{Tor}_i(k, k)) Z^i .$$

Just as  $H(K_R)$ ,  $\text{Tor}^R(k, k)$  is bigraded, so we can define the Poincaré series in two variables (homological and total). If  $y$  is a non-zero divisor of degree one in  $R$ , we have  $P_R(Z) = (1 + Z)P_{R/y}(Z)$ .

A homogeneous element  $y$  of positive degree in  $R = k[X_1, \dots, X_n]/I$  is called a weak non-zero divisor if

$$\text{Ann}_R(\text{Ann}_R y) \cong (x_1, \dots, x_n) ,$$

i.e. if  $\text{Ann}_R y$  is the socle of  $R$ . A sequence  $y_1, \dots, y_k$  in  $R$  is called a weak regular sequence if the image of  $y_i$  in  $R/(y_1, \dots, y_{i-1})$  is a weak non-zero divisor for  $i = 1, \dots, k$ .  $R$  is called a Buchsbaum ring if any system of parameters for  $R$  constitutes a weak regular sequence.

For an ideal  $I \subseteq k[X_1, \dots, X_n]$  we denote the length of a maximal regular sequence in  $I$  by  $\text{gr}(I)$ .

**1. The main theorem and a conjecture.**

**THEOREM.** *If  $R$  is of n.c.  $(n, d, g, (d_1, \dots, d_r))$ , then*

$$\text{Hilb}_R(Z) \geq \frac{1}{(1-Z)^g} \max \left( \left[ \prod_{i=1}^r (1-Z^{d_i}) / (1-Z)^{n-g} \right], 1 / (1-Z)^{d-g} \right).$$

If for a ring  $R$  of n.c.  $(n, d, g, (d_1, \dots, d_r))$  we have equality in the theorem, we call  $R$  extremal of n.c.  $(n, d, g, (d_1, \dots, d_r))$ .

**CONJECTURE.** If there is a Cohen-Macaulay ring (i.e.  $d=g$ ) of n.c.  $(n, d, d, (d_1, \dots, d_r))$ , then there also exists an extremal ring of n.c.  $(n, d, d, (d_1, \dots, d_r))$ .

**OBSERVATION.** It suffices (both in the theorem and the conjecture) to assume  $g=0$ . For suppose the statements are proved for rings of depth  $<g$ . If  $R$  is of n.c.  $(n, d, g, D)$  and  $g>0$  there exists a non-zero divisor  $y$  of degree one in  $R$ . Then the n.c. of  $R/y$  is  $(n-1, d-1, g-1, D)$ , where  $D = (d_1, \dots, d_r)$  so

$$\begin{aligned} \text{Hilb}_{R/y}(Z) &\geq \frac{1}{(1-Z)^{g-1}} \max \left( \left[ \prod_{i=1}^r (1-Z^{d_i}) / (1-Z)^{n-1-(g-1)} \right], \right. \\ &\qquad \qquad \qquad \left. 1 / (1-Z)^{d-1-(g-1)} \right) \\ &= \frac{1}{(1-Z)^{g-1}} \max \left( \left[ \prod_{i=1}^r (1-Z^{d_i}) / (1-Z)^{n-g} \right], 1 / (1-Z)^{d-g} \right), \end{aligned}$$

so

$$\begin{aligned} \text{Hilb}_R(Z) &= \frac{1}{1-Z} \text{Hilb}_{R/y}(Z) \\ &\geq \frac{1}{(1-Z)^g} \max \left( \left[ \prod_{i=1}^r (1-Z^{d_i}) / (1-Z)^{n-g} \right], 1 / (1-Z)^{d-g} \right) \end{aligned}$$

because the series are non-negative.

*In the sequel we always assume  $g=0$ .*

**PROOF OF THE THEOREM.** a)  $\text{Hilb}_R(Z) \geq 1/(1-Z)^d$ : Since  $\dim R = d$  there exist  $d$  algebraically independent (over  $k$ ) elements of degree one in  $R$ , say  $y_1, \dots, y_d$  so

$$\text{Hilb}_R(Z) \geq \text{Hilb}_{k[y_1, \dots, y_d]}(Z) = 1/(1-Z)^d.$$

b) 
$$\text{Hilb}_R(Z) \geq \left[ \prod_{i=1}^r (1 - Z^d)/(1 - Z)^n \right].$$

We need some easy lemmas.

LEMMA 1. *If  $R = k[X_1, \dots, X_n]/(f_1, \dots, f_r)$  and  $S = k[X_1, \dots, X_n]/(g_1, \dots, g_r)$ , where  $(g_1, \dots, g_r)$  is generated by generic forms with  $\deg g_i = \deg f_i$ , then  $\text{Hilb}_S(Z) \leq \text{Hilb}_R(Z)$ .*

PROOF.  $h_k((g_1, \dots, g_r))$  is the number of linearly independent  $m_i g_j$ , where  $m_i$  is a monomial in  $k[X_1, \dots, X_n]$  of degree  $k - \deg g_j$ , and analogously for  $h_k((f_1, \dots, f_r))$ . But if  $\{m_k, f_j; s \in S\}$  are linearly independent, then  $\{m_k g_j; s \in S\}$  are linearly independent because a non-trivial relation of the latter specializes to a relation of the former. This means

$$\text{Hilb}_{(g_1, \dots, g_r)}(Z) \geq \text{Hilb}_{(f_1, \dots, f_r)}(Z)$$

which gives  $\text{Hilb}_S(Z) \leq \text{Hilb}_R(Z)$ .

LEMMA 2. *If  $R$  is a graded ring,  $f$  a form of degree  $d$  in  $R$  and  $\text{Hilb}_R(Z) = \sum_{i \geq 0} a_i Z^i$ , then*

$$\text{Hilb}_{\text{Ann}_R f}(Z) \geq \sum_{i \geq 0} \max(a_i - a_{i+d}, 0) Z^i.$$

PROOF.  $R_i \xrightarrow{f} R_{i+d}$  is a linear map between vector spaces.  $\text{Ker } f$  has dimension at least  $\dim R_i - \dim R_{i+d} = a_i - a_{i+d}$ .

LEMMA 3. *If  $\sum_{i \geq 0} a_i Z^i$  has non-negative coefficients, then*

$$(1 - Z^d) \sum_{i \geq 0} a_i Z^i + \sum_{i \geq 0} \max(a_i - a_{i+d}, 0) Z^{i+d} \geq \left[ (1 - Z^d) \sum_{i \geq 0} a_i Z^i \right].$$

PROOF.

$$\begin{aligned} & (1 - Z^d) \sum a_i Z^i + \sum \max(a_i - a_{i+d}, 0) Z^{i+d} \\ &= \sum (a_i - a_{i-d}) Z^i + \sum \max(a_{i-d} - a_i, 0) Z^i \\ &= \sum (a_i - a_{i-d}) Z^i - \sum \min(a_i - a_{i-d}, 0) Z^i \geq [(1 - Z^d) \sum a_i Z^i]. \end{aligned}$$

LEMMA 4.

$$\left[ (1 - Z^d) \left[ \prod_{i=1}^{r-1} (1 - Z^d)/(1 - Z)^n \right] \right] = \left[ \prod_{i=1}^r (1 - Z^d)/(1 - Z)^n \right].$$

PROOF. Let

$$\prod_{i=1}^{r-1} (1 - Z^{d_i}) / (1 - Z)^n = \sum a_i Z^i .$$

Then

$$\prod_{i=1}^r (1 - Z^{d_i}) / (1 - Z)^n = \sum (a_i - a_{i-d_r}) Z^i ,$$

so

$$\left[ \prod_{i=1}^r (1 - Z^{d_i}) / (1 - Z)^n \right] = \sum c_i Z^i ,$$

where  $c_i = a_i - a_{i-d_r}$ , if  $a_j > a_{j-d_r}$ , for all  $j \leq i$  and  $c_i = 0$  otherwise. Furthermore

$$\left[ \prod_{i=1}^{r-1} (1 - Z^{d_i}) / (1 - Z)^n \right] = \sum b_i Z^i ,$$

where  $b_i = a_i$  if  $a_j > 0$  for all  $j \leq i$  and  $b_i = 0$  otherwise, so

$$(1 - Z^{d_r}) \left[ \prod_{i=1}^{r-1} (1 - Z^{d_i}) / (1 - Z)^n \right] = \sum (b_i - b_{i-d_r}) Z^i$$

and

$$\left[ (1 - Z^{d_r}) \left[ \prod_{i=1}^{r-1} (1 - Z^{d_i}) / (1 - Z)^n \right] \right] = \sum e_i Z^i ,$$

where  $e_i = b_i - b_{i-d_r} = a_i - a_{i-d_r}$ , if  $a_j > a_{j-d_r}$ , and  $a_j > 0$  for all  $j \leq i$  and  $e_i = 0$  otherwise. But for the first index  $i_0$  for which  $a_{i_0} \leq 0$  we also have  $a_{i_0} \leq a_{i_0-d_r}$ , so  $c_i = e_i$  for all  $i$ .

PROOF OF (b). Suppose we have proved the inequality

$$\text{Hilb}_{R'}(Z) \geq \left[ \prod_{i=1}^s (1 - Z^{d_i}) / (1 - Z)^n \right]$$

for generic rings of n.c.  $(d_1, \dots, d_s)$  with  $s < r$ . Now let

$$R = k[X_1, \dots, X_n] / (g_1, \dots, g_r)$$

be generic and

$$R' = k[X_1, \dots, X_n] / (g_1, \dots, g_{r-1}) .$$

Since

$$0 \rightarrow \text{Ann}_{R'} g_r \rightarrow R' \xrightarrow{-g_r} R' \rightarrow R \rightarrow 0$$

is exact we have

$$\text{Hilb}_R(Z) = (1 - Z^{d_r}) \text{Hilb}_{R'}(Z) + Z^{d_r} \text{Hilb}_{\text{Ann}_{R'} \mathfrak{g}}(Z).$$

Let  $\text{Hilb}_{R'}(Z) = \sum a_i Z^i$ . Lemma 2 gives

$$\text{Hilb}_{\text{Ann}_{R'} \mathfrak{g}}(Z) \geq \sum \max(a_i - a_{i+d_r}, 0) Z^i,$$

so

$$\begin{aligned} \text{Hilb}_R(Z) &\geq (1 - Z^{d_r}) \sum a_i Z^i + \sum \max(a_i - a_{i+d_r}, 0) Z^{i+d_r} \\ &= [(1 - Z^{d_r}) \sum a_i Z^i] \quad (\text{Lemma 3}) \\ &\stackrel{!}{\geq} (1 - Z)^{d_r} \left[ \prod_{i=1}^{r-1} (1 - Z^{d_i}) / (1 - Z)^n \right] \quad (\text{by induction since } R' \text{ is generic}) \\ &= \left[ \prod_{i=1}^r (1 - Z^{d_i}) / (1 - Z)^n \right] \quad (\text{Lemma 4}). \end{aligned}$$

Since the inequality is proved for generic rings, it is proved for all rings according to Lemma 1.

NOTE. If we can prove that there are extremal rings of n.c.  $(n, 0, 0, (d_1, \dots, d_{r-1}))$ , we have the *real* inequality in the theorem for all rings of n.c.  $(n, d, 0, (d_1, \dots, d_r))$ , not only the lexicographical.

The following observation is due to L. Avramov.

PROPOSITION 5. Let  $F$  be a prime field and  $c_{ij}$  indeterminates over  $F$ . Let  $g_i = \sum c_{ij} m_{ij}$  be a generic form of degree  $d_i$  for  $1 \leq i \leq r$ . Then  $(g_1, \dots, g_r)$  is a prime ideal in  $F(c_{ij})[X_1, \dots, X_n]$  if and only if  $r \leq n - 1$ .

PROOF.  $(g_1, \dots, g_r)$  can not be prime if  $r \geq n$  since  $F(c_{ij})[X_1, \dots, X_n] / (g_1, \dots, g_r)$  is then Artinian. If  $r \leq n - 1$  we use Theorem 1.1 in [7], which shows that  $(g_1, \dots, g_r)$  is prime in  $F(c_{ij})[X_1, \dots, X_n]$  if and only if  $\text{gr } I_t(A) \geq r + 2 - t$  for  $1 \leq t \leq r$ , where  $I_t(A)$  is the ideal generated by all  $t \times t$ -minors of the matrix

$$A = \begin{bmatrix} X_1^{d_1} \dots X_n^{d_1} & 0 & & & & & 0 \\ 0 & \dots & 0 & X_1^{d_2} \dots X_n^{d_2} & 0 & \dots & 0 \\ & & & & & & \vdots \\ 0 & & & & \dots & X_n^{d_{r-1}} & 0 & \dots & 0 \\ 0 & \dots & & & \dots & 0 & X_1^{d_r} \dots X_n^{d_r} & & \end{bmatrix}$$

The condition  $\text{gr } I_t(A) \geq r + 2 - t$  for  $1 \leq t \leq r$  is easily verified if  $r \leq n - 1$ . (Pick from the first  $t$  rows the columns which contains  $X_i^{d_1}, \dots, X_i^{d_t}$  for  $i = 1, \dots, r + 2 - t$ . These  $t$  minors gives the elements

$$X_i^{\sum_{j=1}^t d_j} \quad \text{for } i = 1, \dots, r + 2 - t,$$

which obviously gives a regular sequence.) But if  $(g_1, \dots, g_r)$  is prime in  $F[c_{ij}][X_1, \dots, X_n]$  it is also prime in  $F(c_{ij})[X, \dots, X_n]$ .

**2. Minimal systems of generators.**

In the theorem we only suppose that the  $f_i$ 's are forms of certain degrees, we do not suppose that the  $f_i$ 's constitute a minimal system of generators for  $(f_1, \dots, f_r)$ . In fact, if for some  $j$

$$\begin{aligned} \max \left( \left[ \prod_{i=1}^r (1 - Z^{d_i}) / (1 - Z)^n \right], 1 / (1 - Z)^d \right) \\ = \max \left( \left[ \prod_{\substack{i=1 \\ i \neq j}}^r (1 - Z^{d_i}) / (1 - Z)^n \right], 1 / (1 - Z)^d \right), \end{aligned}$$

we have no reason to believe that if  $k[X_1, \dots, X_n] / (f_1, \dots, f_n)$  is extremal of n.c.  $(n, d, 0, (d_1, \dots, d_r))$ , then  $(f_1, \dots, f_n)$  is minimally generated. It *could* be as the following example shows:  $k[X_1, X_2] / (X_1^2, X_1 X_2, X_2^3)$  is extremal of n.c.  $(2, 0, 0, (2, 2, 3))$  (as is  $k[X_1, X_2] / (X_1^2, X_2^2, X_2^3)$ ) despite the fact that

$$[(1 - Z^2)^2 (1 - Z^3) / (1 - Z)^2] = [(1 - Z^2)^2 / (1 - Z)^2].$$

On the other hand for the n.c.  $(2, 0, 0, (2, 2, 4))$ , there is no extremal ring with a minimal set of generators: If  $\text{deg } f_1 = \text{deg } f_2 = 2$  and  $f_1, f_2$  have no common factor they constitute a regular sequence and every element of degree 4 in  $k[X_1, X_2] / (f_1, f_2)$  is zero, so e.g.  $k[X_1, X_2] / (X_1^2, X_2^2, X_1^4)$  is extremal. If  $f_1, f_2$  have a common factor of degree one, we can after a linear change of coordinates assume  $f_1 = X_1^2, f_2 = X_1 X_2$  so in this case the only possibility for n.c.  $(2, 0, (2, 2, 4))$  is  $k[X_1, X_2] / (X_1^2, X_1 X_2, X_2^4)$  which is not extremal.

We could, however, say something positive in this context.

LEMMA 6. *If, for all  $j$  we have*

$$\begin{aligned} \max \left( \left[ \prod_{i=1}^r (1 - Z^{d_i}) / (1 - Z)^n \right], 1 / (1 - Z)^d \right) \\ \neq \max \left( \left[ \prod_{\substack{i=1 \\ i \neq j}}^r (1 - Z^{d_i}) / (1 - Z)^n \right], 1 / (1 - Z)^d \right) \end{aligned}$$



and that  $k[X_1, \dots, X_n]/(f_1, \dots, f_n)$  is extremal of n.c.  $(n, d, 0(d_1, \dots, d_r))$ , then the  $f_i$ 's constitute a minimal system of generators.

PROOF. Let

$$R = k[X_1, \dots, X_n]/(f_1, \dots, f_n) \quad \text{and} \quad R_j = k[X_1, \dots, X_n]/(f_1, \dots, \hat{f}_j, \dots, f_n).$$

Then

$$\text{Hilb}_{R_j}(Z) \stackrel{!}{\geq} \max \left( \left[ \prod_{\substack{i=1 \\ i \neq j}}^r (1 - Z^{d_i}) / (1 - Z)^n \right], 1 / (1 - Z)^d \right) \stackrel{!}{>} \text{Hilb}_R(Z).$$

PROPOSITION 7. For  $d > 0$  we have

$$\begin{aligned} \max \left( \left[ \prod_{\substack{i=1 \\ i \neq j}}^r (1 - Z^{d_i}) / (1 - Z)^n \right], 1 / (1 - Z)^d \right) \\ \neq \max \left( \left[ \prod_{i=1}^r (1 - Z^{d_i}) / (1 - Z)^n \right], 1 / (1 - Z)^d \right) \end{aligned}$$

for all  $j$  if  $r \leq n - d + 1$ . For  $d = 0$  we have

$$\left[ \prod_{\substack{i=1 \\ i \neq j}}^r (1 - Z^{d_i}) / (1 - Z)^n \right] \neq \left[ \prod_{i=1}^r (1 - Z^{d_i}) / (1 - Z)^n \right]$$

for all  $j$  if  $r \leq n$  and if  $d_{n+1} = \max \{d_1, d_2, \dots, d_{n+1}\}$ , then

$$\left[ \prod_{\substack{i=1 \\ i \neq j}}^{n+1} (1 - Z^{d_i}) / (1 - Z)^n \right] \neq \left[ \prod_{i=1}^{n+1} (1 - Z^{d_i}) / (1 - Z)^n \right]$$

for all  $j$  if and only if  $d_{n+1} \leq \sum_{i=1}^n d_i - n$ .

PROOF. Let  $d > 0$  and  $s \leq n - d$ . Then

$$\begin{aligned} \left[ \prod_{i=1}^s (1 - Z^{d_i}) / (1 - Z)^n \right] &= \left[ \prod_{i=1}^s (1 + Z + \dots + Z^{d_i-1}) / (1 - Z)^{n-s} \right] \\ &= \prod_{i=1}^s (1 + Z + \dots + Z^{d_i-1}) / (1 - Z)^{n-s} \geq 1 / (1 - Z)^{n-s} \geq 1 / (1 - Z)^d \end{aligned}$$

with the first inequality strict for all terms but the first. Then we have

$$(1 - Z^{d_{s+1}}) \prod_{i=1}^s (1 + Z + \dots + Z^{d_i-1})$$

$$\begin{aligned}
&= \max \left( \left[ \prod_{i=1}^{s+1} (1-Z^{d_i})/(1-Z)^n \right], 1/(1-Z)^d \right) \\
&\neq \max \left( \left[ \prod_{i=1}^s (1-Z^{d_i})/(1-Z)^n \right], 1/(1-Z)^d \right) \\
&= \prod_{i=1}^s (1+Z+\dots+Z^{d_i-1})/(1-Z)^{n-s}
\end{aligned}$$

as long as  $s < n-d$ . For  $s = n-d$

$$\prod_{i=1}^s (1-Z^{d_i})/(1-Z)^n \geq 1/(1-Z)^d,$$

but all coefficients large enough in

$$\prod_{i=1}^{s+1} (1-Z^{d_i})/(1-Z)^n = \prod_{i=1}^{s+1} (1+Z+\dots+Z^{d_i-1})/(1-Z)^{d-1}$$

are smaller than the corresponding coefficient in  $1/(1-Z)^d$ , so

$$\begin{aligned}
\prod_{i=1}^{n-d} (1-Z^{d_i})/(1-Z)^n &= \max \left( \left[ \prod_{i=1}^{n-d} (1-Z^{d_i})/(1-Z)^n \right], 1/(1-Z)^d \right) \\
&\neq \max \left( \left[ \prod_{\substack{i=1 \\ i \neq j}}^k (1-Z^{d_i})/(1-Z)^n \right], 1/(1-Z)^d \right)
\end{aligned}$$

Now suppose  $d=0$ . As above

$$\begin{aligned}
\prod_{i=1}^s (1+Z+\dots+Z^{d_i-1})/(1-Z)^{n-s} &= \prod_{i=1}^s (1-Z^{d_i})/(1-Z)^n \\
\neq \prod_{i=1}^{s+1} (1-Z^{d_i})/(1-Z)^n &= \prod_{i=1}^{s+1} (1+Z+\dots+Z^{d_i-1})/(1-Z)^{n-s-1}
\end{aligned}$$

as long as  $s+1 \leq n$ . Now let  $s = n+1$ . Then

$$\begin{aligned}
\prod_{i=1}^{n+1} (1-Z^{d_i})/(1-Z)^n &= (1-Z^{d_{n+1}}) \prod_{i=1}^n (1+Z+\dots+Z^{d_i-1}) \\
&= (1-Z^{d_{n+1}})(1+nZ+\dots+Z^{\sum_{i=1}^n d_i-n}) \neq 1+nZ+\dots+Z^{\sum_{i=1}^n d_i-n}
\end{aligned}$$

if and only if  $d_{n+1} \leq \sum_{i=1}^n d_i - n$ . Of course, if this inequality is true when  $d_{n+1} = \max \{d_1, \dots, d_{n+1}\}$ , it is true also for every renumbering of the  $d_i$ 's.

**COROLLARY.** *Suppose*

$$\max \left( \left[ \prod_{i=1}^k (1-Z^{d_i})/(1-Z)^n \right], 1/(1-Z)^d \right) \neq \max \left( \left[ \prod_{\substack{i=1 \\ i \neq j}}^k (1-Z^{d_i})/(1-Z)^n \right], 1/(1-Z)^d \right)$$

for every  $j$  but

$$\begin{aligned} \max \left( \left[ \prod_{i=1}^k (1 - Z^{d_i}) / (1 - Z)^n \right], 1 / (1 - Z)^d \right) \\ = \max \left( \left[ \prod_{i=1}^m (1 - Z^{d_i}) / (1 - Z)^n \right], 1 / (1 - Z)^d \right), \end{aligned}$$

for  $m = k + 1, \dots, r$ .

Then, to find an extremal ring of n.c.  $(n, d, 0, (d_1, \dots, d_r))$  it is sufficient to find an extremal ring of n.c.  $(n, d, 0, (d_1, \dots, d_k))$  (which then has a minimally generated ideal).

PROOF. If  $k[X_1, \dots, X_n] / (f_1, \dots, f_k)$  is extremal of n.c.  $(n, d, 0, (d_1, \dots, d_k))$  one can adjoin any forms  $f_{k+1}, \dots, f_r$  which already lies in  $(f_1, \dots, f_k)$  to get an extremal ring of n.c.  $(n, d, 0, (d_1, \dots, d_r))$ . This is possible since for  $k + 1 \leq i \leq r$ ,  $\deg f_i = d_i \geq \min_{1 \leq j \leq k} d_j$  follows from the assumption.

### 3. Examples of extremal rings.

1. If  $R$  is a complete intersection, i.e.  $R$  is of n.c.  $(n, 0, 0, D)$  with  $|D| = n$ , we have

$$\text{Hilb}_R(Z) = \prod_{i=1}^n (1 - Z^{d_i}) / (1 - Z)^n$$

that is  $R$  is extremal.

2. R. Stanley (private communication) has shown that there are extremal rings of n.c.  $(n, 0, 0, D)$  for each  $D$  with  $|D| = n + 1$ . These are almost complete intersections if

$$\max_{1 \leq i \leq n+1} \{d_i\} \leq \sum_{i=1}^{n+1} d_i - n - \max_{1 \leq i \leq n+1} \{d_i\},$$

otherwise complete intersections (not minimally generated) according to Proposition 7. He interpretes  $k[X_1, \dots, X_n] / (X_1^{d_1}, \dots, X_n^{d_n})$  as the cohomology ring of

$$\mathbb{P}^{d_1-1} \times \mathbb{P}^{d_2-1} \times \dots \times \mathbb{P}^{d_n-1}$$

and uses the hard Lefschetz theorem to get an element  $S$  of degree one which is “nearly a non-zerodivisor”. It is easy to see that  $k[X_1, \dots, X_n] / (X_1^{d_1}, \dots, X_n^{d_n}, S^{d_{n+1}})$  is extremal. (In fact in the cohomology ring the  $X_i$ 's and  $S$  have degree 2, but we could divide all degrees by 2.)

3. We now show that

$$R = k[X_1, \dots, X_n]/(X_1^{d_1}, X_2^{d_2} - X_1 X_n^{d_2-1}, X_3^{d_3} - X_2 X_n^{d_3-1}, \dots, \dots, X_{n-1}^{d_{n-1}} - X_{n-2} X_n^{d_{n-1}-1}, X_{n-1} X_n^{d_{n-1}})$$

is an almost complete intersection which is extremal of n.c.  $(n, 1, 0, (d_1, \dots, d_n))$ . (Cf. [4] where this ring for  $(d_1, \dots, d_n) = (2, 2, \dots, 2)$  is studied.) Let

$$R' = k[X_1, \dots, X_n]/(X_1^{d_1}, X_2^{d_2} - (X_1 X_n^{d_2-1}), \dots, X_{n-1}^{d_{n-1}} - X_{n-2} X_n^{d_{n-1}-1}).$$

It is easy to see that  $R'$  is a complete intersection (so  $\text{Hilb}_{R'}(Z) = \prod_{i=1}^{n-1} \frac{1 - Z^{d_i}}{(1 - Z)^{d_i}}$ ) and that the monomials  $x_1^{i_1} x_2^{i_2} \dots x_{n-1}^{i_{n-1}} x_n^j$  with  $i_1 < d_1, \dots, i_{n-1} < d_{n-1}$  and  $j$  arbitrary is a  $k$ -basis for  $R'$ . Now let  $f = x_{n-1} x_n^{d_{n-1}-1}$  in  $R'$ .

$$0 \rightarrow \text{Ann}_{R'} f \rightarrow R' \xrightarrow{f} R' \rightarrow R \rightarrow 0$$

is exact and  $x_1^{d_1-1} x_2^{d_2-1} \dots x_{n-1}^{d_{n-1}-1} x_n^j$  is a  $k$ -basis for  $\text{Ann}_{R'} f$ . Since

$$\text{Hilb}_R(Z) = (1 - Z^{d_n}) \text{Hilb}_{R'}(Z) + Z^{d_n} \text{Hilb}_{\text{Ann}_{R'} f}(Z)$$

and

$$\text{Hilb}_{\text{Ann}_{R'} f}(Z) = Z^{d_1 + d_2 + \dots + d_{n-1} - (n-1)} / (1 - Z)$$

we have that  $R$  is extremal of n.c.  $(n, 1, 0, (d_1, \dots, d_n))$ .

4. If  $(g_1, \dots, g_r)$  is generated by generic forms of degree  $d$  in  $k[X_1, \dots, X_n]$  M. Hochster has shown (not published) that  $\{X_i g_j\}$  are linearly independent if they are not too many, i.e. if

$$rn \leq \binom{n+d}{d+1},$$

and consequently that  $\{X_i g_j\}$  generate everything in degree  $d+1$  if

$$rn \geq \binom{n+d}{d+1}.$$

Now suppose  $R = k[X_1, \dots, X_n]/(g_1, \dots, g_r)$  with  $(g_1, \dots, g_r)$  generated by generic forms of degree  $d$  and

$$r \geq \binom{n+d}{d+1} / n.$$

Then

$$\begin{aligned} \text{Hilb}_R(Z) &= 1 + nZ + \binom{n+1}{2} Z^2 + \dots + \binom{n+d-2}{d-1} Z^{d-1} \\ &\quad + \left( \binom{n+d-1}{d} - r \right) Z^d, \end{aligned}$$

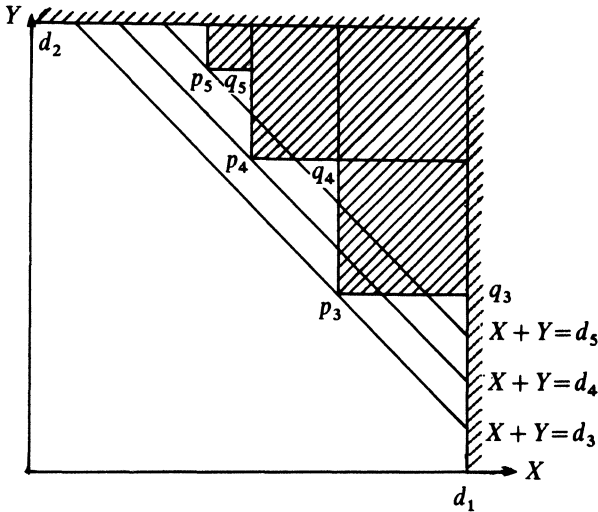

Figure 1

i.e.  $R$  is extremal of n.c.  $(n, 0, 0, (d, d, \dots, d))$ , where  $|(d, d, \dots, d)| = r$ .

5. We will show that for  $n=2$  there exist extremal rings of all possible numerical characters. First we consider the Artinian case, i.e. rings of n.c.  $(2, 0, 0, (d_1, \dots, d_r))$ . Suppose  $d_1 \leq d_2 \leq \dots \leq d_r$ , and that

$$\left[ \prod_{i=1}^{j-1} (1 - Z^{d_i}) / (1 - Z)^2 \right] \neq \left[ \prod_{i=1}^j (1 - Z^{d_i}) / (1 - Z)^2 \right]$$

for all  $j$ , which is sufficient according to section 2. We will make this condition on the  $d_i$ 's more explicit below. We will show that there, for each n.c. exist extremal rings which are monomial rings, i.e. of type  $k[X, Y]/(f_1, \dots, f_n)$  with the  $f_i$ 's monomials. Our method is to find a monomial ring with minimal multiplicity for each n.c. and show that these are extremal. Chose  $f_1 = X^{d_1}$  and  $f_2 = Y^{d_2}$ . Now let

$$R = k[X, Y]/(X^{d_1}, Y^{d_2}, m_3, \dots, m_r),$$

where  $m_i$  is a monomial of degree  $d_i$ . Let

$$m_i = X^{e_i} Y^{d_i - e_i}.$$

Then  $R$  can be represented in a two-dimensional coordinate system as in Fig. 1 (we now suppose  $d_1 \leq d_2 \leq d_i$  for all  $i > 2$ , but have no other restriction). Let  $p_i = (e_i, d_i - e_i)$ ,  $i = 3, \dots, r$ . It is easy to see that the multiplicity of  $R$  is exactly the

area of the non-shaded region in Fig. 1. To minimize the multiplicity thus is to solve the following geometrical problem: Minimize the non-shaded area in the rectangle  $\{(X, Y); 0 \leq X \leq d_1, 0 \leq Y \leq d_2\}$  with the constraints that one corner  $p_3$  lies in an integer point on the line  $X + Y = d_3$ , one corner  $p_4$  lies in an integer point on the line  $X + Y = d_4$  a.s.o. But this is equivalent to maximizing the shaded area within the rectangle with the same constraints. We first solve the problem without restriction on integer solutions. The shaded area in the rectangle is:

$$\begin{aligned}
 & A(e_3, \dots, e_r) \\
 &= (d_1 - d_3)(d_2 - (d_3 - e_3)) + (e_3 - e_4)(d_2 - (d_4 - e_4)) + \dots + \\
 &+ (e_{r-1} - e_r)(d_2 - (d_r - e_r)) = -e_3^2 - e_4^2 - \dots - e_r^2 + e_3 e_4 + e_4 e_5 + e_{r-1} e_r + \\
 &+ e_3(d_1 + d_3 - d_4) + e_4(d_4 - d_5) + e_5(d_5 - d_6) + \dots + e_{r-1}(d_{r-1} - d_r) + e_r(d_r - d_2). \\
 &\quad \frac{\partial A}{\partial e_3} = \frac{\partial A}{\partial e_4} = \dots = \frac{\partial A}{\partial e_r} = 0
 \end{aligned}$$

gives the linear system of equations

$$\begin{bmatrix} -2 & 1 & 0 & 0 & \dots & 0 & 0 \\ 1 & -2 & 1 & 0 & & 0 & 0 \\ 0 & 1 & -2 & 1 & & 0 & 0 \\ \cdot & & & & & & \\ \cdot & & & & & & \\ \cdot & & & & & & \\ 0 & 0 & \dots & 1 & -2 & 1 & \\ 0 & 0 & \dots & 0 & 1 & -2 & \end{bmatrix} \begin{bmatrix} e_3 \\ e_4 \\ \cdot \\ \cdot \\ \cdot \\ \cdot \\ e_r \end{bmatrix} = \begin{bmatrix} d_4 - d_3 - d_1 \\ d_5 - d_4 \\ d_6 - d_5 \\ \cdot \\ \cdot \\ \cdot \\ d_r - d_{r-1} \\ d_2 - d_r \end{bmatrix}$$

or  $Ae = d$ , which has a unique solution since  $\det A = 1/(1-r) \neq 0$ .

The condition for the  $q_i$ 's to lie on the same line  $X + Y = D$  is

$$d_1 + d_3 - e_3 = e_3 + d_4 - e_4 = e_4 + d_5 - e_5 = \dots = e_{r-1} + d_r - e_r = e_r + d_2,$$

which turns out to be exactly the same linear system of equations as above.

It is easy to see that

$$A^{-1} = 1/(1-r) \begin{bmatrix} r-2 & r-3 & \dots & 2 & 1 \\ \cdot & \cdot & & \cdot & \cdot \\ \cdot & \cdot & & \cdot & \cdot \\ \cdot & \cdot & & \cdot & \cdot \\ \cdot & \cdot & & \cdot & \cdot \end{bmatrix}$$

A simple calculation gives  $D = (d_1 + d_2 + \dots + d_r)/(r - 1)$ . This means in particular that, if  $D$  is an integer,  $(x, y)^{D-1} = 0$  but  $\dim_k(x, y)^{D-2} = r - 1$  for  $R$ . We first make the assumption that  $D$  is an integer, that is  $\sum_{i=1}^r d_i \equiv 0 \pmod{r-1}$ , and show that  $R$  is extremal, i.e. that

$$\text{Hilb}_R(Z) = \left[ \prod_{i=1}^r (1 - Z^{d_i}) / (1 - Z)^2 \right],$$

where  $R$  is the monomial ring of minimal multiplicity we just have constructed. We renumber the  $d_i$ 's and assume in the sequel that  $d_1 \leq d_2 \leq \dots \leq d_r$ . Now

$$\begin{aligned} & \left[ \prod_{i=1}^r (1 - Z^{d_i}) / (1 - Z)^2 \right] \\ &= \left[ (1 + Z + \dots + Z^{d_1-1})(1 + Z + \dots + Z^{d_2-1}) \prod_{i=3}^r (1 - Z^{d_i}) \right] \\ &= \left[ (1 + 2Z + 3Z^2 + \dots + d_1 Z^{d_1-1} + d_1 Z^{d_1} + \dots + d_1 Z^{d_2-1} + (d_1 - 1)Z^{d_2} + \dots \right. \\ & \quad \dots \\ & \quad \left. + 2Z^{d_1+d_2-3} + Z^{d_1+d_2-2}) \prod_{i=3}^r (1 - Z^{d_i}) \right]. \end{aligned}$$

We first determine the coefficient  $a_{D-1}$  for  $Z^{D-1}$  (of course  $d_r \leq D - 1 < d_1 + d_2$ ):

$$\begin{aligned} a_{D-1} &= (d_1 + d_2 - D) - (D - d_3) - (D - d_4) - \dots - (D - d_r) \\ &= d_1 + d_2 + \dots + d_r - (r - 1)D = 0. \end{aligned}$$

The coefficient  $a_{D-2}$  for  $Z^{D-2}$  is

$$a_{D-2} = (d_1 + d_2 - D + 1) - (D - d_3 - 1) - \dots - (D - d_r - 1) = r - 1.$$

We will now check the coefficients of  $\text{Hilb}_R(Z)$ , by means of calculating

$$\left[ \prod_{i=1}^r (1 - Z^{d_i}) / (1 - Z)^2 \right] = \sum_{i=0}^{D-2} a_i Z^i.$$

In the interval  $[0, d_1 - 1]$ ,  $a_i$  increases by 1 ( $a_i = i + 1$ ).

In the interval  $[d_1 - 1, d_2 - 1]$ ,  $a_i$  is constant ( $a_i = d_1$ ).

In the interval  $[d_2 - 1, d_3 - 1]$ ,  $a_i$  decreases by 1 ( $a_{d_2-1+i} = d_1 - i$ ).

In the interval  $[d_3 - 1, d_4 - 1]$ ,  $a_i$  decreases by 2 ( $d_{d_3-1+3} = a_{d_3-1} - 2i = d_1 + d_2 - d_3 - 2i$ ).

In general, in the interval  $[d_{k-1} - 1, d_k - 1]$ ,  $a_i$  decreases by  $k - 2$  and

$$a_{d_{k-1}+i} = a_{d_{k-1}-i(k-2)} = d_1 + \dots + d_{k-1} - (k-2)d_k - i(k-2)$$

which one directly sees is the correct Hilbert series for  $R$ .

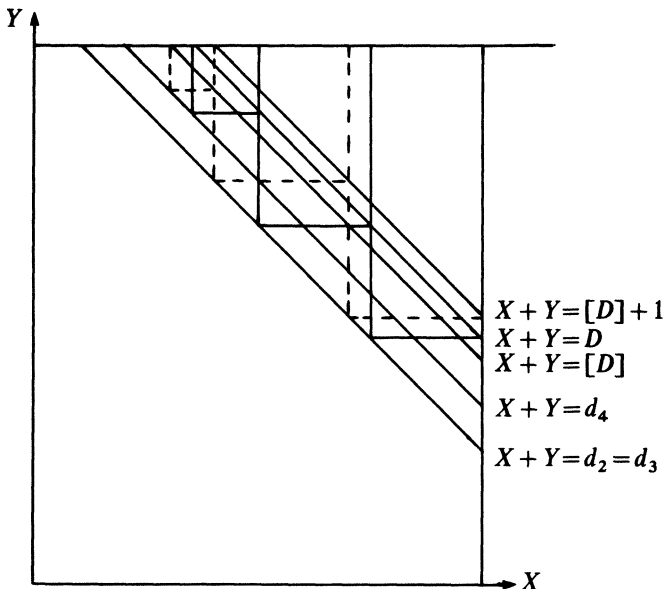

Figure 2

Now let

$$\sum_{i=1}^r d_i \equiv k \pmod{r-1}, \quad k \neq 0.$$

Then the solution of the geometrical problem does not give integer values. One has to move the points according to Figure 2 (in the figure,  $d_1 = 10, d_2 = 12, d_3 = d_4 = 13, d_4 = 14$ ).

The points  $q_1, \dots, q_k$  is moved up to the line  $X + Y = [D] + 1$  and  $q_{k+1}, \dots, q_{r-1}$  down to the line  $X + Y = [D]$ . Let the monomial ring corresponding to this construction be  $R$ . We will check that

$$\text{Hilb}_R(Z) = \left[ \prod_{i=1}^r (1 - Z^{d_i}) / (1 - Z)^2 \right] = \sum a_i Z^i.$$

The coefficient for  $Z^{[D]}$  in

$$\prod_{i=1}^r (1 - Z^{d_i}) / (1 - Z)^2 = (1 + Z + \dots + Z^{d_1-1})(1 + Z + \dots + Z^{d_2-1}) \prod_{i=3}^r (1 - Z^{d_i})$$

is

$$\begin{aligned} & d_1 + d_2 - [D] - 1 - ([D] - d_3 + 1) - ([D] - d_4 + 1) - \dots - ([D] - d_r + 1) \\ &= d_1 + d_2 + \dots + d_r - (r-1)[D] - 1 = k - 1 - (r-1) = k - r < 0 \end{aligned}$$



so  $a_{[D]}=0$ . The coefficient for  $Z^{[D]-1}$  is

$$d_1 + d_2 - [D] - ([D] - d_3) - \dots - ([D] - d_r) \\ = d_1 + d_2 + \dots + d_r - (r-1)[D] = k .$$

The remaining coefficients are checked as above. We are ready with the Artinian case.

Now let n.c.  $R=(2, 1, 0, (d_1, \dots, d_r))$  and let  $R'=k[X, Y]/(m_1, \dots, m_r)$  be extremal of n.c.  $(2, 0, 0, (d_1 - 1, \dots, d_r - 1))$ . (The case  $d_1 = 2$  is easily handled, so we could assume  $d_i - 1 > 1$ ). We will show that

$$R = k[X, Y]/(Xm_1, Xm_2, \dots, Xm_r)$$

is extremal of n.c.  $(2, 1, 0, (d_1, \dots, d_r))$ . It is obvious that n.c.  $R$  is  $(2, 1, 0, (d_1, \dots, d_r))$ .

First one easily observes that one has

$$\text{Hilb}_R(Z) - Z \text{Hilb}_{R'}(Z) = 1/(1 - Z) .$$

(Draw a picture.) Now we know that

$$\text{Hilb}_{R'}(Z) = \left[ \prod_{i=1}^r (1 - Z^{d_i-1}) / (1 - Z)^2 \right] .$$

By checking the coefficients in  $[\prod_{i=1}^r (1 - Z^{d_i}) / (1 - Z)^2]$  and using the connection between  $\text{Hilb}_R(Z)$  and  $\text{Hilb}_{R'}(Z)$  above it is easy to see that

$$\text{Hilb}_R(Z) = \left[ \prod_{i=1}^r (1 - Z^{d_i}) / (1 - Z)^2 \right] ,$$

i.e. that  $R$  is extremal.

Finally we make the condition

$$\left[ \prod_{i=1}^{j-1} (1 - Z^{d_i}) / (1 - Z)^2 \right] \neq \left[ \prod_{i=1}^j (1 - Z^{d_i}) / (1 - Z)^2 \right]$$

for all  $j$  more explicit. From the calculations above it is apparant that (if  $d_1 \leq d_2 \leq \dots \leq d_r$ ) the inequality is equivalent to  $d_j \leq (d_1 + \dots + d_{j-1}) / (j-2) - 2$  if  $(d_1 + \dots + d_{j-1}) / (j-2)$  is an integer and  $d_j \leq [(d_1 + \dots + d_{j-1}) / (j-2)] - 1$  otherwise.

6. The term extremal has been used by P. Schenzel in [9]. His extremal Cohen-Macaulay rings are extremal in our sense of n.c.  $(n, d, d, (f, f, \dots, f))$ , where

$$|(f, f, \dots, f)| = \binom{n-d+k-1}{k}$$

for some  $n, d, k$ . But his extremal Gorenstein rings are not extremal in our sense.

For the rest of this section we suppose  $D = (2, 2, \dots, 2)$ , i.e. all generators for  $I$  are of degree 2, and we write for short n.c.  $R = (n, d, r)$  for  $(n, d, 0, (2, 2, \dots, 2))$  with  $|(2, \dots, 2)| = r$ , that is n.c.  $R = (n, d, r)$  if

$$R = k[X_1, \dots, X_n]/(g_1, \dots, g_r),$$

$\deg g_i = 2$  for  $i = 1, \dots, r$ ,  $\dim R = d$  and  $\text{depth } R = 0$ .

7.

$$k[X_1, \dots, X_n]/(X_1^2, X_2^2, \dots, X_n^2, X_1X_2 + X_3X_4 + \dots + X_{2[n/2]-1}X_{2[n/2]})$$

is extremal of n.c.  $(n, 0, n+1)$ , see [4]. (This is of course a special case of 2. above.) These rings have some odd feature if we allow  $\text{char}(k) \neq 0$ . From [4] it follows that they have different Hilbert series in *all* characteristics  $p$  for  $p < [n/2]$  but their Hilbert series coincide if  $\text{char}(k) = 0$  or  $\text{char}(k) = p > [n/2]$ .

8. If  $\dim R = d$ , we have

$$h_2(R) \geq \binom{d+1}{2},$$

so if  $R$  is extremal of n.c.  $(n, d, r)$ , we have

$$r \leq \binom{n+1}{2} - \binom{d+1}{2},$$

since

$$\text{Hilb}_R(Z) = \max \left( [(1-Z^2)^{-n}/(1-Z)], 1/(1-Z)^d \right).$$

Now suppose

$$r = \binom{n+1}{2} - \binom{d+1}{2}.$$

$k[X_1, \dots, X_n]/((X_1, \dots, X_{n-d}) \cdot (X_1, \dots, X_n))$  is extremal of n.c.

$$\left( n, d, \binom{n+1}{2} - \binom{d+1}{2} \right).$$

9.  $n = 3$ . This is completely covered by the examples above but for the n.c.  $(3, 1, 4)$ .  $k[X_1, X_2, X_3]/(X_1^2, X_1X_2, X_2^2, X_2X_3)$  is extremal of n.c.  $(3, 1, 4)$ .

10.  $n = 4$ . This is covered but for the n.c.'s  $(4, 2, 3)$ ,  $(4, 2, 4)$ ,  $(4, 1, 5)$ ,  $(4, 2, 5)$ ,  $(4, 1, 6)$ ,  $(4, 2, 6)$ ,  $(4, 1, 7)$ , and  $(4, 1, 8)$ .

We can give examples of extremal rings for all these types but  $(4, 2, 3)$ . Let

$$R = k[X_1, X_2, X_3, X_4]/I .$$

N.c.  $I$

$$(4, 2, 4) \quad (X_1^2 - X_2X_4, X_2^2 - X_1X_3, X_1X_4, X_2X_3)$$

$$(4, 1, 5) \quad (X_1^2 - X_2X_4, X_2^2 - X_3X_4, X_3^2 - X_1X_4, X_1X_4 - X_2X_3, X_1X_2)$$

$$(4, 2, 5) \quad (X_1^2 - X_2X_4, X_2^2, X_1X_3, X_1X_4, X_2X_3)$$

$$(4, 1, 6) \quad (X_1^2, X_2^2 - X_1X_4, X_3^2 - X_2X_4, X_1X_2, X_2X_3, X_3X_4)$$

$$(4, 2, 6) \quad (X_1^2, X_2^2, X_1X_3, X_1X_4, X_2X_3, X_2X_4)$$

$$(4, 1, 7) \quad (X_1^2, X_2^2, X_3^2 - X_2X_4, X_1X_2, X_1X_4, X_2X_3, X_3X_4)$$

$$(4, 1, 8) \quad (X_1^2, X_2^2 - X_1X_4, X_3^2, X_1X_2, X_1X_3, X_2X_3, X_2X_4, X_3X_4)$$

We will show in an appendix that there is no extremal ring of n.c. (4, 2, 3).

11. N.c.  $(n, 0, r)$  is covered for  $n \leq 5$ , but for the case  $(5, 0, 7)$

$$k[X_1, \dots, X_5]/(X_1^2, X_2^2, \dots, X_5^2, X_1X_2 + X_3X_4, X_1X_5 + X_2X_3 + X_3X_5 + X_4X_5)$$

is extremal in this case.

**4. Two types of extremal almost complete intersections.**

In this section we make a closer study of extremal rings of numerical chacters  $(n, 0, 0, (d_1, \dots, d_{n+1}))$  and  $(n, 1, 0, (d_1, \dots, d_n))$ , i.e. of extremal almost complete intersections of dimension 0 and 1 respectively. For short we call these rings of type 0 and rings of type 1, respectively. For these rings let

$$c = \sum_{i=1}^{n+1} d_i - (n+1) \quad \text{and} \quad c = \sum_{i=1}^n d_i - n$$

respectively. (In the first case we way as well suppose  $\max \{d_i\} \leq \sum_{i=1}^{n+1} d_i - n$  i.e. that we have minimally generated ideals.)

Before going into details on rings of types 0 and 1, we begin with a general lemma.

**LEMMA 8.** *If  $(f_1, \dots, f_r)$  is an ideal generated by forms of degree  $\geq 1$  in a graded ring  $R$  (or is a proper ideal of a local ring) and if  $\text{gr} (f_1, \dots, f_r) = s$ , there is a set  $\{f'_1, \dots, f'_r\}$  such that  $(f'_1, \dots, f'_r) = (f_1, \dots, f_r)$  and  $f'_1, \dots, f'_r$  is a regular sequence.*

**PROOF.** This is certainly well-known. Use avoidance of primes.

COROLLARY 1. *If  $R$  is a ring of type 0, then  $R$  can be represented as*

$$R = k[X_1, \dots, X_n]/(f_1, \dots, f_{n+1})$$

with  $f_1, \dots, f_n$  a  $k[X_1, \dots, X_n]$ -sequence.

PROOF.

$$\text{gr}(f_1, \dots, f_{n+1}) = \text{height}(f_1, \dots, f_{n+1}) = n$$

( $k[X_1, \dots, X_n]$  being Cohen-Macaulay) so the lemma applies.

COROLLARY 2. *If  $R$  is a ring of type 1, then  $R$  can be represented as*

$$R = k[X_1, \dots, X_n]/(f_1, \dots, f_n)$$

with  $f_1, \dots, f_{n-1}$  a  $k[X_1, \dots, X_n]$ -sequence.

PROOF. Since  $\dim R = 1$  we have  $\text{height}(f_1, \dots, f_n) \leq n-1$  and there is an element  $y$  of degree one in  $R$  for which  $y^j \neq 0$  for all  $j$ . But

$$\text{Hilb}_R(Z) = \prod_{i=1}^n (1 + Z + \dots + Z^{d_i-1}) + Z^{c+1}/(1-Z),$$

so  $R/y$  is Artinian, thus  $\text{height}(f_1, \dots, f_n, y) = n$ , so  $\text{height}(f_1, \dots, f_n) \geq n-1$ . Thus

$$\text{gr}(f_1, \dots, f_n) = \text{height}(f_1, \dots, f_n) = n-1,$$

so the lemma applies.

LEMMA 9. *If  $R = k[Y_1, \dots, Y_n]/(f_1, \dots, f_n)$  is a ring of type 1, we can make a linear change of coordinates  $(x_1, \dots, x_n) = (y_1, \dots, y_n)\mathbf{C}$  so that  $x_n^j \neq 0$  for all  $j$  and so that  $\text{Ann}_R x^{c-1} = (x_1, \dots, x_{n-1})$ .*

PROOF. Since  $\dim R = 1$  there is a  $y$  of degree one in  $R$  such that  $y^j \neq 0$  for all  $j$ . Since  $h_R(i) = 1$  if  $i \geq c$  we have that the element left in degree  $i \geq c$  is  $y^i$ . Now

$$0 \rightarrow \text{Ann}_R y^{c-1} \rightarrow R \xrightarrow{y^{-1}} R \rightarrow R/y^{c-1} \rightarrow 0$$

is exact so

$$\text{Hilb}_{R/y^{c-1}}(Z) = (1 - Z^{c-1}) \text{Hilb}_R(Z) + Z^{c-1} \text{Hilb}_{\text{Ann}_R y^{c-1}}(Z).$$

But

$$\text{Hilb}_{R/y^{c-1}}(Z) = \prod_{i=1}^n (1 + Z + \dots + Z^{d_i-1}) - Z^c - Z^{c-1},$$

so a simple calculation shows that

$$\text{Hilb}_{\text{Ann}_R y^{c-1}}(Z) = (n-1)Z + \dots$$

Now take a  $k$ -basis  $x_1, \dots, x_{n-1}$  for  $\text{Ann}_R y^{c-1}$  in degree 1 and extend it with  $x_n = y$  to get a basis for  $R$  as  $k$ -algebra.

LEMMA 10. *If  $R = k[X_1, \dots, X_n]/(f_1, \dots, f_n)$  is a ring of type 1 we have  $H_{i,j}(K_R) = 0$  if  $j \geq c$ .*

PROOF. We assume  $R$  represented as in the previous lemma. Let  $m_j^i$  be a Koszul monomial  $T_{j_1} \dots T_{j_i}$  of homological degree  $i$  and let  $j \geq c$ . Then

$$m = \sum_I c_j^I x_n^I m_j^I, \quad c_j \in k,$$

is a typical element in  $K_{i,j}$  since  $x_n^j$  is a  $k$ -basis for the elements of degree  $j$  in  $R$ . We see that  $m$  is a cycle if and only if  $m$  is a  $k$ -linear combination of  $x_n^j$  times Koszul monomials in  $T_1, \dots, T_{n-1}$ , since  $x_n^{j+1} \neq 0$  and  $x_i x_n^j = 0$  if  $i < n$ . But then

$$m = d \left( \sum_I c_j^I x_n^{j-1} T_j m_j^I \right)$$

since  $dm \subseteq (x_1, \dots, x_{n-1})K_R$  and  $x_n^{j-1}(x_1, \dots, x_{n-1}) = 0$ .

LEMMA 11. *If  $R = k[X_1, \dots, X_n]/(f_1, \dots, f_{n+1})$  is a ring of type 0, where  $f_1, \dots, f_n$  is a regular sequence, then*

$$R' = k[X_1, \dots, X_n, Y]/(f_1, \dots, f_n, f_{n+1} - Y^{d_{n+1}})$$

*is a complete intersection ( $d_{n+1} = \text{deg } f_{n+1}$ ).*

PROOF.  $f_1, \dots, f_n$  is a regular sequence in  $k[X_1, \dots, X_n]$ , so  $f_1, \dots, f_n$  is a regular sequence in  $k[X_1, \dots, X_n, Y]$ . But  $f_{n+1} - Y^{d_{n+1}}$  is obviously a non-zero divisor in  $k[X_1, \dots, X_n, Y]/(f_1, \dots, f_n)$ .

LEMMA 12. *If  $R = k[X_1, \dots, X_n]/(f_1, \dots, f_n)$  is a ring of type 1, where  $f_1, \dots, f_{n-1}$  is a regular sequence, then*

$$R' = k[X_1, \dots, X_n, Y]/(f_1, \dots, f_{n-1}, f_n - Y^{d_n})$$

*is a complete intersection ( $d_n = \text{deg } f_n$ ).*

PROOF. Analogous.

PROPOSITION 13. *If  $R = k[X_1, \dots, X_n]/(f_1, \dots, f_n)$  is of type 1, then*

- a) In ring degree  $< c-1$   $H(K_R) \cong \bigwedge H_1(K_R)$
- b) In ring degree  $c-1$ ,  $\mu: \bigwedge H_1(K_R) \rightarrow H(K_R)$  is injective
- c) In ring degree  $> c-1$ ,  $H(K_R)=0$ .

PROOF. c) is lemma 10. Let  $R$  and  $R'$  be as in Lemma 12. Then the natural map  $K_{R'} \rightarrow K_R \rightarrow 0$  has kernel  $(y, T_y)K_{R'}$ , where  $dT_y = y$ . This gives the long exact sequence of homology

$$\begin{aligned} \dots \rightarrow H_{i,j}((y, T_y)K_{R'}) &\rightarrow H_{i,j}(K_{R'}) \rightarrow H_{i,j}(K_R) \\ &\rightarrow H_{i-1,j+1}((y, T_y)K_{R'}) \rightarrow \dots \end{aligned}$$

We first show that  $H_{i,j}((y, T_y)K_{R'})=0$  if  $j < c$ . Suppose  $z$  belongs to  $K_{i,j}((y, T_y)K_{R'})$ . Then there is a unique way to write  $z = T_y u + yv$ , where no Koszul monomial in  $v$  is divisible by  $T_y$ . Suppose  $z$  is a cycle. In  $(y, T_y)K_{R'}$ ,

$$z \sim z - d(T_y v) = T_y u + yv - yv + T_y dv = T_y(u - dv) = T_y w.$$

But  $d(T_y w) = yw - T_y dw = 0$ , so  $dw = 0$ , so  $yw = 0$ . So it suffices to show that  $\text{Ann}_{R'} y$  starts in degree  $c$ . We next determine  $\text{Hilb}_{\text{Ann}_{R'} y}(Z)$ . Since

$$0 \rightarrow \text{Ann}_{R'} y \xrightarrow{y} R' \rightarrow R \rightarrow 0$$

is exact, we have

$$\begin{aligned} \text{Hilb}_R(Z) &= (1 - Z) \text{Hilb}_{R'}(Z) + Z \text{Hilb}_{\text{Ann}_{R'} y}(Z) . \\ \text{Hilb}_R(Z) &= \prod_{i=1}^n (1 + Z + \dots + Z^{d_i-1}) + Z^{c+1}/(1 - Z) \end{aligned}$$

and

$$\text{Hilb}_{R'}(Z) = \prod_{i=1}^n (1 + Z + \dots + Z^{d_i-1})$$

gives

$$\text{Hilb}_{\text{Ann}_{R'} y}(Z) = Z^c/(1 - Z)$$

so  $H_{i,j}((y, T_y)K_{R'})=0$  for  $j < c$ . The long exact homology sequence gives a) and b). Observe that the map  $H(K_{R'}) \rightarrow H(K_R)$  is a map of algebras since the kernel is an ideal and that  $H(K_R) \cong \bigwedge H_i(K_R)$ , since  $R'$  is a complete intersection.

COROLLARY. If  $R = k[X_1, \dots, X_n]/(f_1, \dots, f_n)$  is of type 1, we have  $\mu: \bigwedge^{n-1} H_1(K_R) \rightarrow H_{n-1}(K_R)$  injective.

PROOF. Follows from a) and b).

THEOREM 14. *If  $R$  is of type 1,  $H(K_R)$  is completely determined as a bigraded algebra by the numerical characters of  $R$ . Namely, let n.c.  $R = (n, 1, 0, (d_1, \dots, d_n))$ , then as a bigraded algebra*

$$H(K_R) = \left( \left( \bigwedge V \right) / \bigwedge^n V \right) \alpha W,$$

where  $V$  is a vectorspace with a basis  $v_1, \dots, v_n$  with  $v_i$  of bidegree  $(1, d_i - 1)$ , where  $\alpha$  stands for trivial extension, and where  $W$  is a vectorspace with a basis  $w_i^{(j)}$ ,  $2 \leq i \leq n$  and  $1 \leq j \leq \binom{n}{i-1}$  and  $W^2 = 0$ , and where  $w_i^{(j)}$  has bidegree  $(i, c - 1)$ .

PROOF. For any graded algebra  $S$  we have

$$\text{Hilb}_S(Z) = \sum (-1)^i \dim_k H_{i,j}(K_S) Z^{i+j} / (1 - Z)^n,$$

$n = e \cdot \dim S$ . If  $R$  is of type 1 we have

$$\begin{aligned} \text{Hilb}_R(Z) &= \prod_{i=1}^n (1 - Z^{d_i}) / (1 - Z)^n + Z^{c+1} / (1 - Z) \\ &= \left( \prod_{i=1}^n (1 - Z^{d_i}) + Z^{c+1} (1 - Z)^{n-1} \right) / (1 - Z)^n. \end{aligned}$$

If we subtract the contribution of  $\bigwedge^j H_1(K_R)$ ,  $j \leq n - 1$ , we have ( $\bar{H} = H / \bigoplus_{j=1}^{n-1} \bigwedge^j H_1$ )

$$\begin{aligned} \sum_{\substack{(i,j) \\ j \geq c-1}} (-1)^i \dim_k \bar{H}_{i,j}(K_R) Z^{i+j} &= \sum_{\substack{(i,j) \\ j=c-1}} (-1)^i \dim_k \bar{H}_{i,j}(K_R) Z^{i+j} \\ &= (-1)^n Z^{c+n} + Z^{c+1} (1 - Z)^n = \sum_{i=0}^{n-2} (-1)^i \binom{n-1}{i} Z^{i+c+1} \\ &= \sum_{i=2}^n (-1)^i \binom{n-1}{i-2} Z^{i+c-1} \end{aligned}$$

so

$$\dim_k H_{i,c-1}(K_R) = \binom{n-1}{i-2}$$

for  $2 \leq i \leq n$ ,  $i \neq n - 1$ . Since  $H_{i,j}(K_R) = 0$  for  $j > c - 1$  an element in  $W$  annihilates anything of positive ring degree, that is  $V \cdot W = W^2 = 0$ .

COROLLARY. *If  $R = k[X_1, \dots, X_n] / (f_1, \dots, f_n)$  is of type 1,  $\text{Soc } R$  is of  $k$ -dimension  $n - 1$  and is situated in degree  $c - 1$ .*

PROOF.  $\text{Soc } R \cong H_n(K_R)$ .

Rings of type 0 are computationally harder to handle. We choose to make restrictions on their numerical characters to be able to draw nice conclusions instead of getting general but complicated ones.

PROPOSITION 15. *If  $R = k[X_1, \dots, X_n]/(f_1, \dots, f_{n+1})$  is of type 0 with  $n$  even and  $\deg f_i = d$  for all  $i$ ,  $d$  even, then*

- a) *In ring degree  $< (c-1)/2$ ,  $H(K_R) \cong \bigwedge H_1(K_R)$ .*
- b) *In ring degree  $(c-1)/2$ ,  $\mu: \bigwedge H_1(K_R) \rightarrow H(K_R)$  is injective.*
- c) *In ring degree  $> (c-1)/2$ ,  $H(K_R) = 0$ .*

PROOF.

$$\text{Hilb}_R(Z) = [(1 - Z^d)(1 + Z + \dots + Z^{d-1})].$$

If

$$(1 + Z + \dots + Z^{d-1})^n = \sum_{i=0}^{dn-n} a_i Z^i.$$

It is easily shown by induction that  $a_{i-1} < a_i$  for  $i \leq (dn-n)/2$  and that

$$a_{(dn-n)/2+i} = a_{(dn-n)/2-i}.$$

This gives  $h_R((dn-n+d)/2) = 0$  but  $h_R((dn-n+d)/2-1) \neq 0$ . But  $(c-1)/2 = ((n+1)(d-1)-1)/2$  so even  $K_R$  is zero in ring degree  $> (c-1)/2$  which gives c). The proof of a) and b) is completely analogous to the proof in Proposition 13.

COROLLARY. *If  $R$  is as in Proposition 15, we have*

$$\mu: \bigwedge^{n/2} H_1(K_R) \rightarrow H_{n/2}(K_R)$$

*injective.*

PROOF. Follows from a) and b).

THEOREM 16. *If  $R$  is as in Proposition 15,  $H(K_R)$  is completely determined as a bigraded algebra by the numerical characters of  $R$ . Namely*

$$H(K_R) = \left( \left( \bigwedge V \right) / \bigwedge^{n/2+1} V \right) \alpha W$$

*with  $V$  a  $(n+1)$ -dimensional vectorspace in bidegree  $(1, d-1)$ ,  $W$  in bidegrees  $(i, (c-1)/2)$  for  $i=2, \dots, n$  and with  $W^2=0$ .*



PROOF. Analogous to the proof of Theorem 14.

THEOREM 17. *If  $R$  is of type 1, then  $P_R(u, v)$  only depends on the numerical characters of  $R$  and is rational. In fact if  $R$  is of n.c.  $(n, 1, 0, (d_1, \dots, d_n))$ ,*

$$P_R(u, v) = \prod_{i=1}^n (1 + uv^{d_i}) \left/ \left( \prod_{i=1}^n (1 - u^2 v^{d_i}) - u^3 v^{c-1} ((1 + uv)^{n-1} - u^{n-1} v^{n-1}) - u^{2+n} v^n \right) \right.$$

in particular

$$P_R(Z) = (1 + Z)^n / ((1 - Z^2)^n - Z^3((1 + Z)^{n+1} - Z^{n-1}) - Z^{n+2}).$$

PROOF. We will show that there exists a ring homomorphism  $s: H(K_R) \rightarrow Z(K_R)$  such that

$$H(K_R) \xrightarrow{s} Z(K_R) \rightarrow H(K_R)$$

is the identity, where the last map is the natural projection. This is sufficient to have a rational correspondance between  $P_R(Z)$  and  $P_{H(K_R)}(Z, Z)$ , see [1]. Then we will show that  $P_{H(K_R)}(u, v)$  is rational. To construct the map  $s$  we need two lemmas.

LEMMA 18. *If  $R$  is of type 1, then any element  $z$  in  $(Z(K_R))_{i, c-1}$  is homologous to an element in  $S \cdot (K_R)_{i, 0}$ , where  $S = \text{Soc } R$ .*

PROOF. We let  $R$  be represented as in Lemma 9. We have shown that  $S$  has  $k$ -dimension  $n - 1$  and is situated in degree  $c - 1$ . But  $h_R(c - 1) = n$  and  $x_n^{c-1}$  is not in the socle, so  $x_n^{c-1}$  and  $S$   $k$ -generates  $R_{c-1}$ . Now let

$$z = x_n^{c-1} u_0 + \sum_{j=1}^{n-1} s_j u_j,$$

where  $u_j \in (K_R)_{i, 0}$  for  $j = 0, \dots, n - 1$  and  $s_j \in S$ . As in lemma 9 it is clear that  $u_0$  is a  $k$ -linear combination of Koszul monomials in  $T_1, \dots, T_{n-1}$ , but if  $m$  is such a Koszul monomial we have  $dx_n^{c-2} T_n m = x_n^{c-1} m + \sigma$ , where  $\sigma \in S \cdot K_R$ .

LEMMA 19. *If  $R = k[X_1, \dots, X_n]/(f_1, \dots, f_n)$  is of type 1 and represented as in Lemma 9, we have  $f_i \in (X_1, \dots, X_{n-1})$  for  $i = 1, \dots, n$ .*

PROOF. Let  $f_i = c_i X_n^{d_i} + f'_i$ , where  $f'_i \in (X_1, \dots, X_{n-1})$ . Then  $c_i x_n^{d_i} = -\overline{f'_i}$ , but the right hand side belongs to  $(x_1, \dots, x_{n-1}) = \text{Ann}_R x_n^{c-1}$  and the left hand side does not unless  $c_i = 0$ .

We now continue the proof of the theorem. We know that

$$H(K_R) = \left( \left( \bigwedge H_1(K_R) \right) / \bigwedge^n H_1(K_R) \right) \alpha W.$$

Now let  $R$  be represented as in Lemma 9. Then we can lift a basis of  $H_1(K_R)$  to elements of the type  $\sum_{i=1}^n r_i T_i$ , where  $r_i \in (x_1, \dots, x_{n-1})$  according to Lemma 19. We extend this multiplicatively to a lifting of  $(\bigwedge H(K_R)) / \bigwedge^n H_1(K_R)$ . Then a basis of  $W$  is lifted as in Lemma 18. This lifting of  $H(K_R)$  gives the map  $s$ . Now  $H(K_R)$  is an  $M$ -ring (see [5]) modulo the  $n$ th power of the augmentation ideal, hence  $P_{H(K_R)}(u, v)$  and thus  $P_R$  can be calculated (see [8]).

**THEOREM 20.** *If  $R = k[X_1, \dots, X_n] / (f_1, \dots, f_{n+1})$  is of type 0 with  $n$  even and  $d_i = d$  for all  $i$ ,  $d$  even,  $P_R(u, v)$  only depends on  $n$  and  $d$  and is rational.*

**PROOF.** The method of proof is the same as in Theorem 17. Now we can make any lift of a basis for  $H_1(K_R)$  and extend it to  $(\bigwedge H_1(K_R)) / \bigwedge^{n/2+1} H_1(K_R)$  and make any lift of a basis for  $W$  to get the map  $s$ . The rest of the proof is analogous to the proof of Theorem 17.

One way to interpret Proposition 13 is to say that with respect to its Koszul homology a ring of type 1 is close to being Cohen-Macaulay. We will now show that in another respect a ring of type 1 is far from being Cohen-Macaulay.

**THEOREM 21.** *A ring of type 1 of embedding dimension  $\geq 3$  is not Buchsbaum.*

**PROOF.** Let  $R = k[X_1, \dots, X_n] / (f_1, \dots, f_n)$  with  $f_1, \dots, f_{n-1}$  a regular sequence and  $n \geq 3$ . There is a linear form  $Y$  such that  $f_1, \dots, f_{n-1}, Y$  is regular sequence so that  $k[X_1, \dots, X_n] / (f_1, \dots, f_{n-1}, Y)$  is Artinian. Then the image  $y$  in  $R$  of  $Y$  is a parameter since  $R/y$  is Artinian since  $k[X_1, \dots, X_n] / (f_1, \dots, f_n, Y)$  is Artinian. Now suppose

$$\text{Ann}_R y = \text{Ann}_R (x_1, \dots, x_n) = \text{Soc } R.$$

Since

$$0 \rightarrow \text{Ann}_R y \rightarrow R \xrightarrow{y} R \rightarrow R/y \rightarrow 0$$

is exact we have

$$\begin{aligned} \text{Hilb}_{R/y}(Z) &= (1 - Z) \text{Hilb}_R(Z) + Z \text{Hilb}_{\text{Soc } R}(Z) \\ &= (1 - Z) \left( \prod_{i=1}^n (1 + Z + \dots + Z^{d_i-1}) + Z^{c+1} / (1 - Z) \right) + (n - 1) Z^c. \end{aligned}$$

But if some  $d_i > 2$  or  $n > 3$  the coefficient of  $Z^{c-1}$  is negative and we have a contradiction. But if  $d_i = 2$  for all  $i$  and  $n = 3$  there are only two extremal rings ([2]), namely  $k[X_1, X_2, X_3]/(X_1^2, X_2^2 - X_1X_3, X_2X_3)$  and  $k[X_1, X_2, X_3]/(X_1, X_2, (X_1 + X_2)X_3, X_1^2 + X_1X_3 + X_2^2)$ . But in these rings  $x_3$  is a parameter annihilated by  $x_2$  and by  $(x_1 + x_2)$  respectively, and the socle is generated by two elements of degree 2.

NOTE. We have assumed the field  $k$  to be the complex numbers. In fact, any field will do except in examples 2 and 7 where  $\text{char } k = 0$  is needed, and in Theorem 21, where  $k$  algebraically closed is needed.

APPENDIX. We will show that there exists no extremal ring of n.c.  $(4, 2, 0, (2, 2, 2))$ . (There exist rings of this n.c., e.g.  $k[X, \dots, X_4]/(X_1^2 - X_3^2, X_2^2 - X_4^2, X_1X_4 - X_2X_3)$ , see [6].) Suppose  $k[X_1, \dots, X_4]/(f_1, f_2, f_3)$  were extremal with  $f_1, f_2$  a  $k[X_1, \dots, X_4]$ -sequence. Exactly as in section 4 one sees that  $R' = k[X_1, \dots, X_n, Y]/(f_1, f_2, f_3 - Y^2)$  is a complete intersection. As before one calculates

$$\text{Hilb}_{\text{Ann}_{R'}(Z)} = Z^7 + \dots$$

and has  $K_R \cong K_{R'}$  in ring degrees  $< 6$ . If  $s \in \text{Soc } R$ , then  $\text{deg } s \leq 6$ , since  $\dim R/s = 2$  and

$$\text{Hilb}_{R/s}(Z) = \text{Hilb}_R(Z) - Z^{\text{deg } s},$$

which is too small if  $\text{deg } s > 6$ . The same argument shows that the socle has  $k$ -dimension 1. We have shown that  $H_{4,j}(K_R) = 0$  if  $j > 6$ . Next we will show that  $H_{3,j}(K_R)$  and  $H_{2,j}(K_R)$  are zero for  $j > 6$ . Suppose

$$Z = r_1T_1T_2T_3 + r_2T_1T_2T_4 + r_3T_1T_3T_4 + r_4T_2T_3T_4$$

is a homogeneous cycle of ring degree  $m > 6$  and that  $x_3, x_4$  are algebraically independent. Then we have

$$r_i = \sum_{j=0}^m c_{ij}x_4^{m-j}.$$

We can reduce  $Z$  with a boundary to get a homologous cycle

$$Z' = cx_3^mT_1T_2T_3 + r'_2T_1T_2T_4 + r'_3T_1T_3T_4 + r'_4T_2T_3T_4.$$

Now

$$dZ' = (cx_3^{m+1} + r'_2x_4)T_1T_2 + \dots = 0$$

gives  $c = r'_2 = 0$ , so

$$Z' = r'_3 T_1 T_3 T_4 + r'_4 T_2 T_3 T_4,$$

hence

$$dZ' = x_4 r'_3 T_1 T_3 + x_4 r'_4 T_2 T_3 + \dots = 0$$

gives  $r'_3 = r'_4 = 0$ . Now let

$$Z = r_1 T_1 T_2 + r_2 T_1 T_3 + r_3 T_1 T_4 + r_4 T_2 T_3 + r_5 T_2 T_4 + r_6 T_3 T_4$$

be a homogeneous cycle of ring degree  $m > 6$ . We can reduce  $Z$  by a boundary to

$$Z' = cx_3^m T_1 T_3 + r'_3 T_1 T_4 + r'_4 T_2 T_3 + r'_5 T_2 T_4 + r'_6 T_3 T_4.$$

The coefficient of  $T_1$  in  $dZ' = 0$  gives  $c = r'_3 = 0$ , so

$$Z' = r'_4 T_2 T_3 + r'_5 T_2 T_4 + r'_6 T_3 T_4.$$

The coefficient of  $T_2$  in  $dZ'$  is  $-x_3 r'_4 + x_4 r'_5$  so we could reduce by a boundary to get  $Z' \sim Z'' = r''_6 T_3 T_4$ . Finally  $dZ'' = 0$  gives  $r''_6 = 0$ . Using the same method as before we have

$$\dim_k H_0(K_R), \dim_k H_1(K_R), \dim_k H_2(K_R), \dim_k H_3(K_R), \dim_k H_4(K_R) \\ = (1, 3, 4, 3, 1).$$

But this is impossible according to [3].

#### REFERENCES

1. L. L. Avramov, *Small homomorphisms of local rings*, J. Algebra 50 (1978), 400–453.
2. J. Backelin and R. Fröberg, *Studies on some  $k$ -algebras giving the Poincaré series of graded  $k$ -algebras of length  $\leq 7$  and local rings of embedding dimension 3 with  $m^3 = 0$* , Preprint no. 9, Matematiska Institutionen, Stockholms Universitet, 1978.
3. E. G. Evans and P. Griffith, *The syzygy problem*, Ann. of Math. 114 (1981), 323–333.
4. R. Fröberg, *Extremal almost complete intersections*, Preprint no. 18, Matematiska Institutionen, Stockholms Universitet, 1981.
5. R. Fröberg, *Some complex constructions with applications to Poincaré series*, in *Séminaire d'algèbre Paul Dubreil* (Proc. Paris, 1979–78), ed. M. P. Malliarin, (Lecture Notes in Math. 740), pp. 272–284, Springer-Verlag, Berlin - Heidelberg - New York, 1979.
6. T. H. Gulliksen, *Tout idéal premier d'un anneau nothérien est associé à un idéal engendré par trois éléments*, C. R. Acad. Sci. Paris Sér A 271 (1970), 1206–1207.
7. C. Huneke, *On the symmetric algebra of a module*, J. Algebra 69 (1981), 113–119.
8. C. Löffwall, *On the subalgebra generated by the one-dimensional elements in the Yoneda Ext-algebra*, Preprint no. 5, Matematiska Institutionen, Stockholms Universitet, 1976.
9. P. Schenzel, *Über die freien Auflösungen extremaler Cohen-Macaulay-Ringe*, J. Algebra 64 (1980), 93–101.
10. H. Wiebe, *Über homologische Invarianten lokaler Ringe*, Math. Ann. 179 (1969), 257–274.