

THE WEIGHTED POINCARÉ INEQUALITIES

RITVA HURRI

1. Introduction.

We consider the weighted Poincaré inequalities:

$$(1.1) \quad \left(\int_D |u(x) - u_{D,\alpha}|^p d(x, \partial D)^\alpha dx \right)^{1/p} \leq c \left(\int_D |\nabla u(x)|^p d(x, \partial D)^\alpha dx \right)^{1/p}$$

and

$$(1.2) \quad \left(\int_D |u(x) - u_{D,\alpha}|^p d(x, \partial D)^\alpha dx \right)^{1/p} \leq c \left(\int_D |\nabla u(x)|^p dx \right)^{1/p}$$

where the number $u_{D,\alpha}$ is the weighted average of u over D :

$$u_{D,\alpha} = \left(\int_D d(x, \partial D)^\alpha dx \right)^{-1} \int_D u(x) d(x, \partial D)^\alpha dx.$$

In particular we are interested in the metric properties of domains D where (1.1) and (1.2) hold in appropriate Sobolev classes.

If $\alpha = 0$, inequality (1.1), as well as (1.2), reduces to the ordinary Poincaré inequality.

We write $\mathcal{P}_{p,\alpha}^1$ (respectively $\mathcal{P}_{p,\alpha}^2$) for the class of bounded domains satisfying inequality (1.1) (respectively (1.2)). We give sufficient conditions of combinatoric nature for $D \in \mathcal{P}_{p,\alpha}^1$ and for $D \in \mathcal{P}_{p,\alpha}^2$, see Theorems 3.2 and 3.4. In particular, domains satisfying both a quasihyperbolic boundary condition and a Whitney cube #-condition belong to $\mathcal{P}_{p,\alpha}^1$ and $\mathcal{P}_{p',\alpha'}^2$ for some α and α' , see Theorems 4.1 and 4.2. John domains are examples of such domains, see Section 5.

Weighted inequalities have been studied earlier by T. Horiuchi [Ho], T.

Iwaniec and C. A. Nolder [IN], A. Kufner and B. Opic [KO], and V. G. Maz'ya [Maz], for example.

The author wishes to thank Professor Olli Martio for helpful comments.

2. Preliminaries.

2.1. NOTATION. Throughout this paper we let D be a domain of euclidean n -space \mathbb{R}^n , $n \geq 2$, with finite measure. We suppose that $\alpha \in \mathbb{R}$, unless otherwise stated, and $p \in [1, \infty)$.

In this paper a Whitney decomposition of D into non-overlapping dyadic closed cubes is denoted as W . For the construction of a Whitney decomposition see [S, VI].

The space $L^p(D, \alpha)$ is a set of functions u on D such that

$$\|u\|_{L^p(D, \alpha)} = \left(\int_D |u(x)|^p d(x, \partial D)^\alpha dx \right)^{1/p} < \infty.$$

The weighted Sobolev space $W_p^1(D, \alpha)$ is the space of functions $u \in L^p(D, \alpha)$ whose first distributional partial derivatives belong to $L^p(D, \alpha)$. In $W_p^1(D, \alpha)$ we use the norm

$$\|u\|_{W_p^1(D, \alpha)} = \|u\|_{L^p(D, \alpha)} + \|\nabla u\|_{L^p(D, \alpha)}.$$

We set $L^p(D) = L^p(D, 0)$ and $W_p^1(D) = W_p^1(D, 0)$; these are the ordinary Lebesgue and Sobolev spaces, respectively.

The weighted average of a function u over D is

$$u_{D, \alpha} = \left(\int_D d(x, \partial D)^\alpha dx \right)^{-1} \int_D u(x) d(x, \partial D)^\alpha dx,$$

where we suppose

$$\int_D d(x, \partial D)^\alpha dx < \infty.$$

If a bounded domain D satisfies a Whitney cube #-condition, then this integral is finite also for some $\alpha < 0$, see Section 4. We write $u_D = u_{D, 0}$.

We let $c(*, \dots, *)$ denote a constant which depends only on the quantities appearing in the parentheses.

The following lemma will be used frequently.

2.2. LEMMA. If $u \in L^p(D, \alpha)$, $\alpha \in \mathbb{R}$, then

$$\|u - u_{D, \alpha}\|_{L^p(D, \alpha)} \leq 2 \|u - c\|_{L^p(D, \alpha)}$$

for each $c \in \mathbb{R}$.

PROOF. By the Minkowski inequality

$$\|u - u_{D, \alpha}\|_{L^p(D, \alpha)} \leq \|u - c\|_{L^p(D, \alpha)} + \|c - u_{D, \alpha}\|_{L^p(D, \alpha)}.$$

The Hölder inequality yields

$$\begin{aligned} \|u_{D, \alpha} - c\|_{L^p(D, \alpha)} &= \left(\int_D \left| \frac{1}{\int_D d(y, \partial D)^\alpha dy} \int_D u(y) d(y, \partial D)^\alpha dy - c \right|^p d(x, \partial D)^\alpha dx \right)^{1/p} \\ &= \frac{1}{\int_D d(y, \partial D)^\alpha dy} \left(\int_D \left| \int_D (u(y) - c) d(y, \partial D)^\alpha dy \right|^p d(x, \partial D)^\alpha dx \right)^{1/p} \\ &\leq \left(\int_D d(y, \partial D)^\alpha dy \right)^{1/p-1} \left(\int_D 1 \cdot |u(y) - c|^p d(y, \partial D)^\alpha dy \right)^{1/p} \\ &\leq \left(\int_D d(y, \partial D)^\alpha dy \right)^{1/p-1+1-1/p} \left(\int_D |u(y) - c|^p d(y, \partial D)^\alpha dy \right)^{1/p} = \|u - c\|_{L^p(D, \alpha)}. \end{aligned}$$

3. Sufficient conditions.

We apply some methods used in [Hu, Sections 4 and 6]:

Let D be a domain and W its Whitney decomposition. Write tQ for the cube with the same center as Q and expanded by a factor $t > 1$. Fix $Q_0 \in W$ and $x_0 \in Q_0$. Join Q_0 to $Q \in W$ with a chain of expanded Whitney cubes $\frac{2}{3}Q_j$, $j = 0, 1, \dots, k$, $Q_k = Q$, such that

$$Q_i \cap Q_j \neq \emptyset \quad \text{if and only if} \quad |i - j| \leq 1,$$

see [Hu, the proof for Proposition 6.1]. This construction of expanded Whitney cubes is called a chain, abbreviated $C(Q_k) = (Q_0, Q_1, \dots, Q_k)$. We let $\ell(C(Q_k)) = k$ denote the length of the chain $C(Q_k)$.

For each $Q \in W$ we fix a chain $C(Q)$. For a fixed cube $A \in W$ we write

$$A(W) = \{Q \in W \mid A \in C(Q)\}.$$

3.1. LEMMA. For each $Q \in W$ and $u \in W_p^1(D, \alpha)$

$$\int_{\frac{9}{8}Q} |u(y) - u_{\frac{9}{8}Q}|^p d(y, \partial D)^\alpha dy \leq c(n, p) \text{dia}(Q)^p \int_{\frac{9}{8}Q} |\nabla u(y)|^p d(y, \partial D)^\alpha dy$$

and for $u \in L^p(D, \alpha)$ such that $|\nabla u| \in L^p(D)$

$$\int_{\frac{9}{8}Q} |u(y) - u_{\frac{9}{8}Q}|^p d(y, \partial D)^\alpha dy \leq c(n, p) \text{dia}(Q)^{\alpha+p} \int_{\frac{9}{8}Q} |\nabla u(y)|^p dy.$$

PROOF. For each $y \in \frac{9}{8}Q$

$$\frac{1}{4} \leq \frac{d(y, \partial D)}{\text{dia}(Q)} \leq 20.$$

Thus $u \in W_p^1(\text{int } \frac{9}{8}Q)$ (in both cases) and the Poincaré inequality without weights in a cube yields the claims.

The quasihyperbolic distance between points x_1 and x_2 in D is given by

$$k_D(x_1, x_2) = \inf_{\gamma} \int_{\gamma} \frac{ds}{d(x, \partial D)}$$

where the infimum is taken over all rectifiable curves γ joining x_1 and x_2 in D . For the properties of k_D see [GP] and [GO].

3.2. THEOREM. Suppose that D is a domain in \mathbb{R}^n , $x_0 \in D$, and let $p \in [1, \infty)$. Suppose that

$$(3.3) \quad \int_D k_D(x_0, x)^{p-1} d(x, \partial D)^\alpha dx < \infty.$$

If $p \geq n + \alpha$, then $D \in \mathcal{P}_{p, \alpha}^1$.

If $p \geq \max\{-\alpha, n\}$, then $D \in \mathcal{P}_{p, \alpha}^2$.

3.4. THEOREM. Suppose that D is a domain in \mathbb{R}^n , $x_0 \in D$.

(i) Let $p \in [1, \infty)$. If for some constant c

$$(3.5) \quad \sum_{Q \in \mathcal{A}(W)} \int_{\frac{9}{8}Q} (k_D(x_0, x) + 1)^{p-1} d(x, \partial D)^\alpha dx \leq c \text{dia}(A)^{n+\alpha-p}$$

whenever $A \in W$, then $D \in \mathcal{P}_{p, \alpha}^1$.

(ii) Let $p \in [\max\{-\alpha, 1\}, \infty)$. If for some constant c

$$(3.6) \quad \sum_{Q \in \mathcal{A}(W)} \int_{\frac{9}{8}Q} (k_D(x_0, x) + 1)^{p-1} d(x, \partial D)^\alpha dx \leq c \operatorname{dia}(A)^{n-p}$$

whenever $A \in W$, then $D \in \mathcal{P}_{p,\alpha}^2$.

We note that for $\alpha = 0$ Theorems 3.2 and 3.4 reduce to Theorem 6.7 (P_1), (P_3) in [Hu].

PROOF OF THEOREMS 3.2 AND 3.4. Let $Q_0 \in W$ be such that $x_0 \in Q_0$. By Lemma 2.2 it suffices to estimate

$$\int_D |u(y) - u_{\frac{9}{8}Q_0}|^p d(y, \partial D)^\alpha dy.$$

We shall employ properties of Whitney cubes.

First

$$(3.7) \quad \int_D |u(y) - u_{\frac{9}{8}Q_0}|^p d(y, \partial D)^\alpha dy = \sum_{Q \in \mathcal{W}} \int_Q |u(y) - u_{\frac{9}{8}Q_0}|^p d(y, \partial D)^\alpha dy \\ \leq 2^{p-1} \left(\sum_{Q \in \mathcal{W}} \int_{\frac{9}{8}Q} |u(y) - u_{\frac{9}{8}Q}|^p d(y, \partial D)^\alpha dy + \sum_{Q \in \mathcal{W}} \int_{\frac{9}{8}Q} |u_{\frac{9}{8}Q} - u_{\frac{9}{8}Q_0}|^p d(y, \partial D)^\alpha dy \right).$$

By Lemma 3.1

$$(3.8) \quad \sum_{Q \in \mathcal{W}} \int_{\frac{9}{8}Q} |u(y) - u_{\frac{9}{8}Q}|^p d(y, \partial D)^\alpha dy \\ \leq c_1(n, p, \alpha) \sum_{Q \in \mathcal{W}} \operatorname{dia}(Q)^p \int_{\frac{9}{8}Q} |\nabla u(y)|^p d(y, \partial D)^\alpha dy \\ \leq c_2(n, p, \alpha) \operatorname{dia}(D)^p \int_D |\nabla u(y)|^p d(y, \partial D)^\alpha dy$$

and

$$(3.9) \quad \sum_{Q \in \mathcal{W}} \int_{\frac{9}{8}Q} |u(y) - u_{\frac{9}{8}Q}|^p d(y, \partial D)^\alpha dy$$

$$\begin{aligned} &\leq c_3(n, p, \alpha) \sum_{Q \in \mathcal{W}} \text{dia}(Q)^{p+\alpha} \int_{\frac{9}{8}Q} |\nabla u(y)|^p dy \\ &\leq c_4(n, p, \alpha) \text{dia}(D)^{p+\alpha} \int_D |\nabla u(y)|^p dy, \end{aligned}$$

if $p + \alpha \geq 0$.

To estimate the last sum in (3.7) we fix $Q \in \mathcal{W}$ and join Q_0 to Q with the chain $C(Q_0) = (Q_0, Q_1, \dots, Q_k)$, $Q_k = Q$. Write

$$u_j = u_{\frac{9}{8}Q_j} = \int_{\frac{9}{8}Q_j} u(y) dy.$$

Now the ordinary Poincaré inequality in a cube yields

$$\begin{aligned} |u_{\frac{9}{8}Q} - u_{\frac{9}{8}Q_0}|^p &\leq \left(\sum_{j=1}^k |u_j - u_{j-1}| \right)^p \leq k^{p-1} \sum_{j=1}^k |u_j - u_{j-1}|^p \\ &= k^{p-1} \sum_{j=1}^k \int_{\frac{9}{8}Q_{j-1} \cap \frac{9}{8}Q_j} |u_j - u_{j-1}|^p dy \\ &= (2k)^{p-1} \sum_{j=1}^k \frac{1}{|\frac{9}{8}Q_{j-1} \cap \frac{9}{8}Q_j|} \left(\int_{\frac{9}{8}Q_{j-1}} |u_{j-1} - u(y)|^p dy + \int_{\frac{9}{8}Q_j} |u_j - u(y)|^p dy \right) \\ &\leq c_5(n, p) k^{p-1} \sum_{j=0}^k \text{dia}(Q_j)^{p-n} \int_{\frac{9}{8}Q_j} |\nabla u(y)|^p dy \end{aligned}$$

Write $k = \ell(C(Q))$; now

$$\begin{aligned} (3.10) \quad &\sum_{Q \in \mathcal{W}} \int_{\frac{9}{8}Q} |u_{\frac{9}{8}Q} - u_{\frac{9}{8}Q_0}|^p d(y, \partial D)^\alpha dy \\ &= c_5(n, p) \sum_{Q \in \mathcal{W}} \int_{\frac{9}{8}Q} \ell(C(Q))^{p-1} d(y, \partial D)^\alpha dy \sum_{A \in C(Q)} \text{dia}(A)^{p-n} \int_{\frac{9}{8}A} |\nabla u(x)|^p dx; \end{aligned}$$

and changing the order of summation we obtain

$$\begin{aligned}
 (3.11) \quad & \sum_{Q \in \mathcal{W}} \int_{\frac{9}{8}Q} |u_{\frac{9}{8}Q} - u_{\frac{9}{8}Q_0}|^p d(y, \partial D)^\alpha dy \\
 & \leq c_5(n, p) \sum_{A \in \mathcal{W}} \sum_{Q \in \mathcal{A}(W)} \int_{\frac{9}{8}Q} \ell(C(Q))^{p-1} d(y, \partial D)^\alpha dy \operatorname{dia}(A)^{p-n} \int_{\frac{9}{8}A} |\nabla u(x)|^p dx.
 \end{aligned}$$

Next we shall employ the inequality ([Hu, Proposition 6.1])

$$\ell(C(Q)) \leq c(n)(k_D(x_0, x) + 1) \quad \text{for each } x \in Q.$$

If $p \geq n + \alpha$, we obtain from (3.10)

$$\begin{aligned}
 & \sum_{Q \in \mathcal{W}} \int_{\frac{9}{8}Q} \ell(C(Q))^{p-1} d(y, \partial D)^\alpha dy \sum_{A \in \mathcal{C}(Q)} \operatorname{dia}(A)^{p-n-\alpha} \int_{\frac{9}{8}A} |\nabla u(x)|^p d(x, \partial D)^\alpha dx \\
 & \leq c_6 \operatorname{dia}(D)^{p-n-\alpha} \sum_{Q \in \mathcal{W}} \int_{\frac{9}{8}Q} (k_D(x_0, x) + 1)^{p-1} d(x, \partial D)^\alpha dx \int_D |\nabla u(x)|^p d(x, \partial D)^\alpha dx,
 \end{aligned}$$

where $c_6 = c_6(\alpha, n, p)$. This together with (3.3), (3.7) and (3.8) yields $D \in \mathcal{P}_{p, \alpha}^1$, if $p \geq n + \alpha$. If $p \geq \max\{-\alpha, n\}$, then (3.3), (3.7), (3.9) and (3.10) imply $D \in \mathcal{P}_{p, \alpha}^2$. Hence Theorem 3.2 is proved.

From (3.11) we obtain

$$\begin{aligned}
 & \sum_{Q \in \mathcal{W}} \int_{\frac{9}{8}Q} |u_{\frac{9}{8}Q} - u_{\frac{9}{8}Q_0}|^p d(y, \partial D)^\alpha dy \\
 & \leq c_7 \sum_{A \in \mathcal{W}} \sum_{Q \in \mathcal{A}(W)} \int_{\frac{9}{8}Q} (k_D(x_0, x) + 1)^{p-1} d(x, \partial D)^\alpha dx \operatorname{dia}(A)^{p-n-\alpha} \int_{\frac{9}{8}A} |\nabla u(x)|^p d(x, \partial D)^\alpha dx.
 \end{aligned}$$

where $c_7 = c_7(\alpha, n, p)$. This together with (3.5), (3.7) and (3.8) implies $D \in \mathcal{P}_{p, \alpha}^1$. If $p + \alpha \geq 0$, then (3.6), (3.7), (3.9) and (3.11) yield $D \in \mathcal{P}_{p, \alpha}^2$. Thus Theorem 3.4 is proved.

4. Domains satisfying (3.3), (3.5) or (3.6).

Here we give examples of domains which satisfy the conditions in Theorems 3.2 and 3.4. These examples show that the Poincaré domains can be quite non-smooth.

John domains. [MS] A domain D is called an (α, β) -John domain, $0 < \alpha \leq \beta < \infty$, if there is $x_0 \in D$ such that each $x \in D$ can be joined to x_0 by

a curve $\gamma: [0, \ell] \rightarrow D$ parametrized by arc length with $\ell \leq \beta$ and

$$d(\gamma(t), \partial D) \geq \frac{\alpha}{\ell} t, \quad t \in [0, \ell].$$

Domains satisfying a quasihyperbolic boundary condition. A domain D satisfies a quasihyperbolic boundary condition with a constant $a > 0$, if there exists a point x_0 such that

$$k_D(x_0, x) \leq a \log \left(1 + \frac{|x_0 - x|}{\min \{d(x, \partial D), d(x_0, \partial D)\}} \right)$$

for all $x \in D$, see [GM, 3.6], [HV, Section 2] and [Hu, 7.2].

John domains form a proper subclass of domains satisfying a quasihyperbolic boundary condition.

Plumpness. Following O. Martio and J. Väisälä [MaVä, 2.1] we say that a domain D is α -plump, $0 < \alpha \leq 1$, if there is $\sigma > 0$ such that for every $y \in \partial D$ and for all $t \in (0, \sigma]$ there is $x \in D \cap B^n(y, t)$ with $d(x, \partial D) > \alpha t$.

We consider only bounded domains satisfying a quasihyperbolic boundary condition.

Whitney cube #-condition ([MaVu, 2.1]). Suppose that for a bounded domain D

$$D = \bigcup_{k=1}^{\infty} \bigcup_{j=1}^{N_k} Q_j^k$$

where the Whitney decomposition W of D is arranged in such a way that the Whitney cubes Q_j^k satisfy

$$\text{dia}(Q_j^k) = \text{dia}(D)2^{-k}, \quad j = 1, \dots, N_k.$$

A domain D is said to satisfy a *Whitney cube #-condition* with $\lambda < n$, if there are constants $M < \infty$ and $\lambda \in (0, n)$ such that

$$N_k \leq M2^{k\lambda} \quad \text{for each } k.$$

A John domain satisfies a Whitney cube #-condition, [MaVu, Lemmas 6.3 and 2.8], and, more generally, if a domain D is plump, then it satisfies a Whitney cube #-condition, see [MaVu, 2.7 and Lemma 2.8].

4.1. THEOREM. *Let D be a domain in \mathbb{R}^n satisfying a quasihyperbolic boundary condition with a constant a and a Whitney cube #-condition with $\lambda < n$. Let $\alpha > \lambda - n$. Now (i) $D \in \mathcal{P}_{p,\alpha}^1$ for each $p \geq \alpha + n$ and (ii) $D \in \mathcal{P}_{p,\alpha}^2$ for each $p \geq n$.*

PROOF FOR THE CLAIM (i). Write $c_0 = \sup_{x \in D} d(x, \partial D)/d(x_0, \partial D)$.

The quasihyperbolic boundary condition yields

$$\begin{aligned} \int_D k_D(x_0, x)^{p-1} d(x, \partial D)^\alpha dx &= \sum_{Q \in W} \int_Q k_D(x_0, x)^{p-1} d(x, \partial D)^\alpha dx \\ &\leq a^{p-1} \sum_{Q \in W} \int_Q \left(\log \left(1 + \frac{c_0 |x_0 - x|}{d(x, \partial D)} \right) \right)^{p-1} d(x, \partial D)^\alpha dx \end{aligned}$$

and the Whitney cube #-condition gives

$$\begin{aligned} &\sum_{Q \in W} \int_Q k_D(x_0, x)^{p-1} d(x, \partial D)^\alpha dx \\ &\leq a^{p-1} \sum_{k=1}^\infty \sum_{j=1}^{N_k} \left(\log \frac{2c_0 \operatorname{dia}(D)}{\operatorname{dia}(Q_j^k)} \right)^{p-1} |Q_j^k| \operatorname{dia}(Q_j^k)^\alpha \\ &\leq c \sum_{k=1}^\infty k^{p-1} 2^{k(\lambda-n-\alpha)} < \infty, \end{aligned}$$

where the constant c depends on $n, p, a, \lambda, d(x_0, \partial D)$, and $\operatorname{dia}(D)$. Thus Theorem 3.2 yields $D \in \mathcal{P}_{p,\alpha}^1$.

A similar estimate as above also yields the claim (ii).

If instead of the Whitney cube #-condition plumpness is used, then we obtain better estimates than in Theorem 4.1 for the exponents α and p .

4.2. THEOREM. *Let D be a domain in \mathbb{R}^n satisfying a quasihyperbolic boundary condition with a constant a , let D be β -plump, and let $\varepsilon = (\log(1 + (\beta/24)^n))/\log(120/\beta)$ and $p \in [1, \infty)$.*

(i) *If $\alpha > -\varepsilon$ and $p > (\alpha + n) \left(1 - \frac{1}{2a} \right) - \frac{\varepsilon}{2a}$, then $D \in \mathcal{P}_{p,\alpha}^1$.*

(ii) *If $\alpha > \max\{-\varepsilon, -p\}$ and $p > n - (\alpha + \varepsilon + n)/2a$, then $D \in \mathcal{P}_{p,\alpha}^2$.*

For the proof we decompose D into Whitney cubes and construct chains as explained at the beginning of Section 3. We need the following lemma.

4.3. LEMMA ([Hu, Lemma 7.27]). *Suppose that D satisfies a quasihyperbolic boundary condition and D is β -plump. Then for each $A \in W$*

$$\sum_{Q \in B_j} |Q| \leq c 2^{-j\varepsilon} \operatorname{dia}(A)^{(n+\varepsilon)/2a}$$

where

$$B_j = \left\{ Q \in A(W) \mid 2^{-j} \leq \frac{\operatorname{dia}(Q)}{c_1 \operatorname{dia}(A)^{1/a}} \leq 2^{-j+1} \right\},$$

$j = 1, 2, \dots$; constants c and c_1 depend at most on $n, p, \beta, d(x_0, \partial D)$ and $\operatorname{dia}(D)$.

PROOF OF (i) IN THEOREM 4.2. Fix $A \in \mathcal{W}$. Write $c_0 = \sup_{x \in D} d(x, \partial D)/d(x_0, \partial D)$.

Constants c_i , $i = 1, 2, 3$, below depend at most on $n, p, \alpha, \beta, a, d(x_0, \partial D)$, and $\text{dia}(D)$. The quasihyperbolic boundary condition and Lemma 4.3 imply

$$\begin{aligned} & \sum_{Q \in B_j} \int_{\frac{9}{8}Q} (k_D(x_0, x) + 1)^{p-1} d(x, \partial D)^\alpha dx \\ & \leq c_1 \sum_{Q \in B_j} \left(\log \frac{2ec_0 \text{dia}(D)}{\text{dia}(Q)} \right)^{p-1} \text{dia}(Q)^\alpha |Q| \\ & \leq \frac{c_2}{\delta} j^{p-1} 2^{-j(\alpha+\varepsilon)} \text{dia}(A)^{(n+\varepsilon)/2a+\alpha/a-\delta} \end{aligned}$$

where $0 < \delta < (n + \varepsilon)/2a + \alpha/a$. Summing over $j = 1, 2, \dots$ we obtain

$$\sum_{Q \in \mathcal{A}(W)} \int_{\frac{9}{8}Q} (k_D(x_0, x) + 1)^{p-1} d(x, \partial D)^\alpha dx \leq \frac{c_3}{\delta} \text{dia}(A)^{(n+\varepsilon)/2a+\alpha/a-\delta},$$

see [Hu, Lemma 7.13]. Theorem 3.4 yields the claim (i).

The proof for the claim (ii) in Theorem 4.2 is analogous.

4.4. REMARK. If $D \subset \mathbb{R}^n$ is a John domain with a Whitney cube #-constant $\lambda < n$ and if $\delta \in (\lambda - n, \infty)$, then $D \in \mathcal{P}_{p,\delta}^1$ for each $p \geq 1$, see Theorem 5.2. The following example shows that the lower bound for p in Theorems 4.1 (i) and 4.2 (i) is essentially sharp for a non-John domain.

4.5. EXAMPLE. Let G_0 be the open rectangle bounded by the lines

$$x_1 = 0, x_2 = 0, x_1 = 1, x_2 = -1$$

and for $j = 1, 2, \dots$ let G_j be the open triangle bounded by

$$x_1 = 2^{-2j}, x_2 = 2^{-2j} - 2^{-2bj}, x_1 + x_2 = 2^{-2j} - 2^{-2bj},$$

where $b \geq 2$ is a constant; cf. [GM, Example 2.2b]. Denote by G^* the reflection of the domain $\bigcup_{j=0}^{\infty} G_j$ with respect to the line $x_2 = -\frac{1}{2}$. Set

$$G = \bigcup_{j=0}^{\infty} G_j \cup G^*.$$

Let $T: \mathbb{R}^2 \rightarrow \mathbb{R}^2$ be a translation such that $T(x_1, x_2) = (x_1, x_2 + \frac{1}{2})$. Set $D = T(G)$.

The domain D satisfies a quasihyperbolic boundary condition with $a = 36b$ and also a Whitney cube #-condition for some $\lambda_0 \in [1, 2)$. Thus by Theorem 4.1 (i)

$D \in \mathcal{P}_{p,\delta}^1$ at least for each $p \geq 2 + \delta$, where $\delta \in (2 - \lambda, 0]$, $\lambda \in [\lambda_0, 2)$ will be fixed later. We show that $D \notin \mathcal{P}_{p,\delta}^1$, if $p < 2 + \delta - \frac{1}{2b}(4 + \delta)$.

Let G_j^1 be the open set bounded by the lines

$$x_1 = 2^{-2j}, x_2 = 2^{-2j} - 2^{-2bj}, x_2 = 2^{-2bj}, x_1 + x_2 = 2^{-2j} - 2^{-2bj}.$$

Let G_j^{1*} be the image of G_j^1 under reflection across the line $x_2 = -\frac{1}{2}$. Set $T(G_j^1) = D_j^1$ and $T(G_j \setminus (G_j^1 \cap G_0)) = D_j^2$ and $T(G_j^{1*}) = D_j^{1*}$ and $T(G_j^* \setminus (G_j^{1*} \cap G_0)) = D_j^{2*}$, see Figure 4.1.

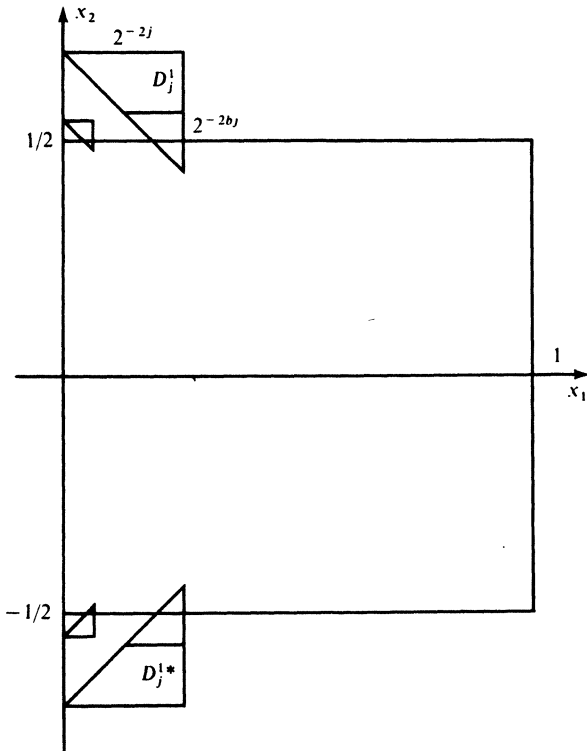

Figure 4.1.

Fix D_j^2 , $j = 1, \dots$. Now D_j^2 is an (α_j, β_j) -John domain with $\alpha_j = \frac{1}{2} 2^{-2bj}$ and $\beta_j = 3 \cdot 2^{-2bj}$. Let $W(D_j^2)$ be a Whitney decomposition of D_j^2 . The proofs of [MaVu, Lemmas 6.3 and 2.8] yield that

$$\#\{Q \in W(D_j^2) \mid \text{dia}(Q) = \text{dia}(D_j^2) 2^{-k}\} \leq A 2^{1k},$$

$k = 1, 2, \dots$, and $\lambda_1 < 2$. Constants $c_i, i = 1, \dots, 5$, depend at most on δ, p , and G . Set $\lambda = \max\{\lambda_0, \lambda_1\}$. Now

$$\begin{aligned}
 (4.6) \quad \int_{D_j^2} d(x, \partial D_j^2)^\delta dx &= \sum_{Q \in \mathcal{W}(D_j^2)} \int_Q d(x, \partial D_j^2)^\delta dx \\
 &= \sum_{k=1}^{\infty} \sum_{\substack{Q \in \mathcal{W}(D_j^2) \\ \text{dia}(Q) = \text{dia}(D_j^2)2^{-k}}} \int_Q d(x, \partial D_j^2)^\delta dx \leq c_1 \text{dia}(D_j^2)^{2+\delta} \sum_{k=1}^{\infty} 2^{-(2+\delta-\lambda)k} \\
 &= c_2 \text{dia}(D_j^2)^{2+\delta} = c_3 2^{-2b(2+\delta)j},
 \end{aligned}$$

if $\delta > \lambda - 2$.

Fix $\delta \in (\lambda - 2, 0]$. Choose a piecewise linear continuous function $u: D \rightarrow \mathbb{R}$ such that

$$u(x) = \begin{cases} 2^{(4+2\delta)j} & \text{in } D_j^1, j = 1, 2, \dots \\ 0 & \text{in } \{(x_1, x_2) \mid x_1 \in (0, 1), x_2 \in (-\frac{1}{2}, \frac{1}{2})\} \\ -2^{(4+2\delta)j} & \text{in } D_j^{1*}, j = 1, 2, \dots \end{cases}$$

Now $u_D = 0$ and

$$\begin{aligned}
 \int_D |u(x)|^p d(x, \partial D)^\delta dx &\geq \sum_{j=1}^{\infty} \int_{D_j^1} 2^{(4+2\delta)j} d(x, \partial D)^\delta dx \\
 &\geq \sum_{j=1}^{\infty} 2^{(4+2\delta)j} (2 \cdot 2^{-2j})^\delta |D_j^1| = c_4 \sum_{j=1}^{\infty} 2^{2(2+\delta)j} 2^{-2(2+\delta)j} = \infty.
 \end{aligned}$$

On the other hand,

$$\begin{aligned}
 \int_D |\nabla u(x)|^p d(x, \partial D)^\delta dx &= 2 \sum_{j=1}^{\infty} \int_{D_j^2} 2^{(4+\delta+2bp)j} d(x, \partial D)^\delta dx \\
 &\leq 2 \sum_{j=1}^{\infty} 2^{(4+\delta+2bp)j} \int_{D_j^2} d(x, \partial D_j^2)^\delta dx
 \end{aligned}$$

and by (4.6)

$$\int_D |\nabla u(x)|^p d(x, \partial D)^\delta dx \leq c_5 \sum_{j=1}^{\infty} 2^{(4+\delta+2bp-4b-2b\delta)j} < \infty,$$

if $p < 2 + \delta - \frac{1}{2b}(4 + \delta)$. Hence $D \notin \mathcal{P}_{p,\delta}^1$, if $p < 2 + \delta - \frac{1}{2b}(4 + \delta)$.

5. The weighted Poincaré inequality in John domains.

We will show that an (α, β) -John domain $D \in \mathcal{P}_{p,\gamma}^1$ for each $p \in [1, \infty)$ whenever $\gamma \in (c(n, \beta/\alpha), \infty)$ where $c(n, \beta/\alpha) < 0$ is a constant. Our method is based on a potential estimate and the method of Martio [M], and it differs from that used in Section 3.

5.1. THEOREM. Let D be a bounded domain in \mathbb{R}^n and let W be its Whitney decomposition. If D satisfies a Whitney cube \sharp -condition, with constants $M < \infty$ and $\lambda < n$ such that

$$\#\{Q \in W \mid \text{dia}(Q) = \text{dia}(D)2^{-j}\} \leq M2^{\lambda j}$$

for each $j = 1, 2, \dots$, then for all $y \in D$

$$(5.2) \quad \int_D |x - y|^{1-n} d(x, \partial D)^\gamma dx \leq c(n, \gamma, \lambda) M^{1/(2n-1)} \text{dia}(D) d(y, \partial D)^\gamma$$

where $(\lambda - n)/2n < \gamma \leq 0$.

PROOF. Let $x, y \in D$. Since D is bounded,

$$d(y, \partial D) \leq \text{dia}(D)^{2n/(2n-1)} d(x, \partial D)^{1/(1-2n)}$$

for all $x, y \in D$. Thus

$$\begin{aligned} \int_D |x - y|^{1-n} d(x, \partial D)^\gamma dx &= \int_D |x - y|^{1-n} d(x, \partial D)^{\gamma/(1-2n)} d(x, \partial D)^{\gamma(1-1/(1-2n))} dx \\ &\leq \text{dia}(D)^{2n\gamma/(1-2n)} d(y, \partial D)^\gamma \int_D |x - y|^{1-n} d(x, \partial D)^{2n\gamma/(2n-1)} dx. \end{aligned}$$

By the Hölder inequality with exponents $(2n - 1)/2(n - 1)$ and $2n - 1$

$$\begin{aligned} &\int_D |x - y|^{1-n} d(x, \partial D)^{2n\gamma/(2n-1)} dx \\ &\leq \left(\int_D |x - y|^{(1-2n)/2} dx \right)^{2(n-1)/(2n-1)} \left(\int_D d(x, \partial D)^{2n\gamma} dx \right)^{1/(2n-1)} \end{aligned}$$

where

$$\begin{aligned} \int_D |x - y|^{(1-2n)/2} dx &\leq \int_{B^n(y, (|D|/\Omega_n)^{1/n})} |x - y|^{(1-2n)/2} dx \\ &= c_1(n) \int_0^{(|D|/\Omega_n)^{1/n}} \rho^{n-1+\frac{1}{2}-n} d\rho = c_2(n) |D|^{\frac{1}{2n}}. \end{aligned}$$

Using a Whitney decomposition W of D we obtain

$$\begin{aligned} \int_D d(x, \partial D)^{2n\gamma} dx &= \sum_{j=1}^{\infty} \sum_{\substack{Q \in W \\ \text{dia}(Q) \\ = \text{dia}(D)2^{-j}}} \int_Q d(x, \partial D)^{2n\gamma} dx \\ &\leq M \text{dia}(D)^{n(1+2\gamma)} \sum_{j=1}^{\infty} 2^{-j(n+2n\gamma-\lambda)} < \infty, \end{aligned}$$

if $n + 2n\gamma - \lambda > 0$.

The above inequalities yield (5.2) and the theorem is proved.

5.3. THEOREM. Let $p \in [1, \infty)$. An (α, β) -John domain D belongs to $\mathcal{P}_{p,\gamma}^1$ where $(\lambda - n)/2n < \gamma \leq 0$ and $\lambda = \lambda(n, \beta/\alpha) < n$ is the Whitney cube #-constant.

PROOF. Let x_0 be a John center and let $x \in D$. Now [M, Theorem 2.2] implies that there is an L-bilipschitz mapping T_x of $B^n(0, \alpha)$ into D such that $T_x(0) = x_0$, $x \in T_x(B^n(0, \alpha))$, and $L = c(n) \left(\frac{\beta}{\alpha}\right)^4$. Write $A = T_x(B^n(0, \alpha))$ and $E = B^n\left(x_0, c(n) \frac{\alpha^5}{\beta^4}\right)$.

Let $u \in W_p^1(D, d(x, \partial D)^\gamma)$. The proofs of [M, Lemmas 2.3, 2.4 and 2.5] yield that $\bar{A} \subset D$. Hence $u \in W_p^1(A, d(x, \partial D)^\gamma)$ and the norms $\|u\|_{W_p^1(A, d(x, \partial D)^\gamma)}$ and $\|u\|_{W_p^1(A)}$ are equivalent. Thus $W_p^1(A, d(x, \partial D)^\gamma) = \overline{C^\infty(A)}$, where the closure is taken with respect to the norm $\|\cdot\|_{W_p^1(A, d(x, \partial D)^\gamma)}$. Hence we obtain from [M, Lemma 3.3]

$$|u(x) - u_E| \leq c_1(n, \alpha, \beta) \int_A |x - y|^{1-n} |\nabla u(y)| dy \leq c_2(n, \alpha, \beta) \int_D |x - y|^{1-n} |\nabla u(y)| dy$$

for x . Since $x \in D$ was an arbitrary point,

$$|u(x) - u_E| \leq c_2(n, \alpha, \beta) \int_D |x - y|^{1-n} |\nabla u(y)| dy$$

for each $x \in D$.

The Hölder inequality yields

$$\begin{aligned}
 |u(x) - u_E|^p &\leq c_2(n, \alpha, \beta) \left(\int_D (|x - y|)^{1-1/p} (|x - y|^{1-n})^{1/p} |\nabla u(y)| dy \right)^p \\
 &\leq c_2(n, \alpha, \beta) \left(\int_D |x - y|^{1-n} dy \right)^{p-1} \int_D |x - y|^{1-n} |\nabla u(y)|^p dy,
 \end{aligned}$$

where

$$\int_D |x - y|^{1-n} dy \leq \int_{B^n(x, (|D|/\Omega_n)^{1/n})} |x - y|^{1-n} dy \leq n\Omega_n (|D|/\Omega_n)^{1/n}.$$

Multiplying with $d(x, \partial D)^\gamma$ on both sides of the inequality

$$|u(x) - u_E|^p \leq c_3(n, p, \alpha, \beta) |D|^{(p-1)/n} \int_D |x - y|^{1-n} |\nabla u(y)|^p dy$$

and integrating over D with respect to the variable x and using Fubini's theorem we obtain

$$\begin{aligned}
 &\int_D |u(x) - u_E|^p d(x, \partial D)^\gamma dx \\
 &\leq c_3(n, p, \alpha, \beta) |D|^{(p-1)/n} \int_D \left(\int_D |x - y|^{1-n} |\nabla u(y)|^p dy \right) d(x, \partial D)^\gamma dx \\
 &= c_3(n, p, \alpha, \beta) |D|^{(p-1)/n} \int_D |\nabla u(y)|^p \left(\int_D |x - y|^{1-n} d(x, \partial D)^\gamma dx \right) dy
 \end{aligned}$$

An (α, β) -John domain satisfies a Whitney cube $\#$ -condition with $\lambda = \lambda(n, \beta/\alpha) < n$ and $M = M(n, \alpha, \beta)$ [MaVu, Lemmas 6.3 and 2.8]. Thus Theorem 5.1 implies

$$\int_D |x - y|^{1-n} d(x, \partial D)^\gamma dx \leq c_4(n, \alpha, \beta, \gamma) \text{dia}(D) d(y, \partial D)^\gamma$$

where $(\lambda - n)/2n < \gamma \leq 0$. Thus combining the above inequalities we obtain

$$\int_D |u(x) - u_E|^p d(x, \partial D)^\gamma dx$$

$$\begin{aligned} &\leq c_5(n, p, \alpha, \beta, \gamma) |D|^{(p-1)/n} \text{dia}(D) \int_D |\nabla u(y)|^p d(y, \partial D)^\gamma dy \\ &\leq c_6(n, p, \alpha, \beta, \gamma) \text{dia}(D)^p \int_D |\nabla u(y)|^p d(y, \partial D)^\gamma dy. \end{aligned}$$

Lemma 2.2 completes the proof.

5.4. REMARK. Theorem 3.4 (i) and [Hu, Lemmas 8.3 and 8.4] yield that an (α, β) -John domain D belongs to $\mathcal{P}_{p,\gamma}^1$ for all $p \geq 1$, if $\gamma \geq 0$.

REFERENCES

- [GO] F. W. Gehring and B. G. Osgood, *Uniform domains and quasihyperbolic metric*, J. Analyse Math. 36 (1979), 50–74.
- [GP] F. W. Gehring and B. P. Palka, *Quasiconformally homogeneous domains*, J. Analyse Math. 30 (1976), 172–199.
- [HV] D. A. Herron and M. Vuorinen, *Positive harmonic functions in uniform and admissible domains*, Analysis 8 (1988), 187–206.
- [Ho] T. Horiuchi, *The imbedding theorems for weighted Sobolev spaces*, Report No. 9, Institut Mittag-Leffler, 1987.
- [Hu] R. Hurri, *Poincaré domains in \mathbb{R}^n* , Ann. Acad. Sci. Fenn. Ser. A I Math. Dissertationes, no. 71, 1988.
- [IN] T. Iwaniec and C. A. Nolder, *Hardy-Littlewood inequality for quasiregular mappings in certain domains in \mathbb{R}^n* , Ann. Acad. Sci. Fenn. Ser. A I Math. 10 (1985), 267–282.
- [KO] A. Kufner and B. Opic, *Some inequalities in weighted Sobolev spaces*, Constructive Theory of Functions '84, Sofia, 644–648.
- [M] O. Martio, *John domains, bilipschitz balls and Poincaré inequality*, Rev. Roumaine Math. Pures Appl. 33 (1988) 1–2, 107–112.
- [MS] O. Martio and J. Sarvas, *Injectivity theorems in plane and space*, Ann. Acad. Sci. Fenn. Ser. A I Math. 4 (1978–79), 383–401.
- [MaVu] O. Martio and M. Vuorinen, *Whitney cubes, p -capacity and Minkowski content*, Exposition. Math. 5 (1987), 17–40.
- [MaVä] O. Martio and J. Väisälä, *Elliptic equalities and maps of bounded length distortion*, Math. Ann. 282 (1988), 423–443.
- [Maz] V. G. Maz'ya, *Sobolev Spaces*, Springer Verlag, Berlin–Heidelberg–New York–Tokyo, 1985.
- [S] E. M. Stein, *Singular Integrals and Differentiability Properties of Functions*, Princeton Univ. Press, Princeton, New Jersey, 1970.